

Technical Description And User Manual

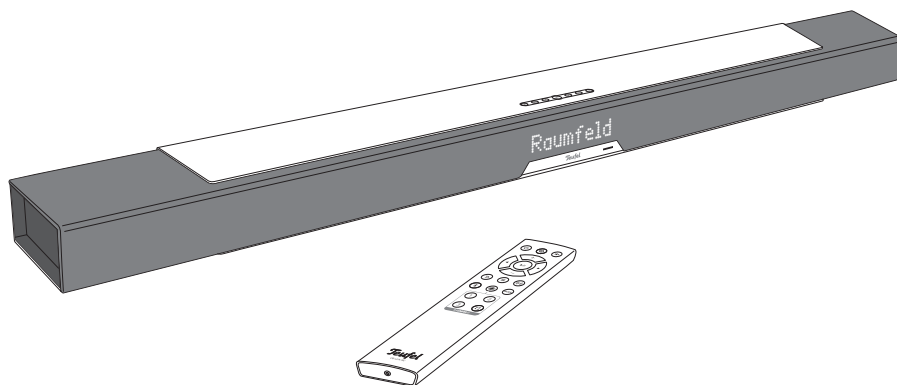

Cinebar LUX

2.1 Soundbar with wireless technology

Teufel

Contents

General Notes And Information	3	Adjusting the volume.....	22
Notice.....	3	Adjusting the volume of the	
Trademarks	3	optional speakers.....	22
Original packaging.....	3	Mute.....	22
Complaints	4	Adjusting the sound	22
Contact	4	Equalizer	23
For Your Safety.....	5	Stereo widening.....	23
Proper use	5	Dolby Audio and Dolby mode.....	23
Explanation of terms.....	5	Menu	24
Safety notes.....	6	“Sound” menu	25
Explanation of symbols.....	9	“Speaker” menu	25
Overview	10	“System” menu.....	27
Unpacking.....	10	Spotify	28
Package contents	10	Setting up Raumfeld.....	29
Checking the package contents.....	10	Bluetooth® Mode.....	30
Controls And Connections.....	11	Bluetooth® options	30
Remote Control	13	Pairing and connecting	30
Inserting/changing the		Playback.....	31
batteries	14	Interruption of connection	31
Setup/Wall Mounting	15	Terminating the connection	31
Setup location	15	Software Update	32
Location tips.....	15	Installing new software	
Wall mounting.....	15	automatically.....	32
Connecting	17	Installing Updates without a	
TV set	18	Connection to the Internet	32
HDMI source.....	18	Care And Cleaning	33
Optical-digital source.....	18	Troubleshooting	34
Analogue source.....	19	Technical Data.....	36
Subwoofer.....	19	Declaration Of Conformity	37
Network.....	19	Disposal.....	37
USB	19	Important information in	
Rear speakers	20	accordance with the Electrical	
Power supply	20	and Electronic Equipment Act	
Operation.....	21	(Germany: ElektroG).....	37
Activating and deactivating	21	Important information about the	
Selecting a source.....	21	Batteries Act (Germany: BattG)	38

General Notes And Information

Notice

The information in this document may change without prior notice and in no way constitutes any liability on the part of Lautsprecher Teufel GmbH.

No part of this user manual may be reproduced in any form or be broadcasted in any way electronically, mechanically, by photocopy or recording without the written permission of Lautsprecher Teufel GmbH.

© Lautsprecher Teufel GmbH
Version 2.2, May 2022

Trademarks

® All trademarks are the property of their respective owners.

 **Bluetooth**® The Bluetooth® word mark and Bluetooth® symbol are registered trademarks of Bluetooth SIG, Inc. and any use by Lautsprecher Teufel is licensed.

The Spotify software is subject to third-party licences, which are listed here:

www.spotify.com/connect/third-party-licenses



DOLBY AUDIO Manufactured under licence from Dolby Laboratories. Dolby, Dolby Audio, Pro Logic and the double D symbol are trademarks of Dolby Laboratories.



For DTS patents, see <http://patents.dts.com>. Manufactured under license from DTS Licensing Limited. DTS, the Symbol, DTS and the Symbol together, and Digital Surround are registered trademarks or trademarks of DTS, Inc. in the United States and/or other countries. © DTS, Inc. All Rights Reserved.



The HDMI and High-Definition Multimedia Interface terms as well as the HDMI logo are trademarks or registered trademarks of HDMI Licensing Administrator Inc. in the USA and other countries.

Original packaging

If you wish to exercise your right of return, we ask that you be absolutely sure to hold onto the packaging. We can only accept product returns with the ORIGINAL PACKAGING.

Empty boxes are not available!

Complaints

In case of a complaint we will need the following information to process your enquiry:

1. Invoice number

Can be found on the sales slip (enclosed with the product) or on the order confirmation received as a PDF document, e.g. 4322543

2. Serial number or batch number

Located on the back side of the device, e.g. serial no.: KB20240129A-123.

Thank you for your support!

Contact

Please contact our customer service department with any questions, suggestions, or complaints:

Lautsprecher Teufel GmbH
BIKINI Berlin
Budapester Str. 44
10787 Berlin (Germany)

Telephone: 00800 200 300 40 (toll-free)

Fax: +49 (0)30 / 300 930 930

Online support:

www.teufelaudio.com/service

Contact form:

www.teufelaudio.com/contact



Before operating the product for the first time, please read the safety notes and user manual carefully. This is the only way to use all functions safely and reliably. Store the user manual in a safe place and also be sure to pass it on to any subsequent owner.

NOTICE

Check that all items have been delivered and that nothing is damaged. If you find any damage, do not operate the device; instead contact our customer service department.

For Your Safety

Proper use

The speaker is designed for the playback of music and speech from an external player.

Only use the speaker as described in this user manual. Any other use will be deemed as not in accordance with the instructions and may lead to damage to property or even persons.

The manufacturer accepts no liability for damage caused by improper use.

The speaker is intended for private use.

Explanation of terms

You can find the following signal terms in this user manual:

WARNING

This signal term indicates a moderate risk, which, if not avoided, may result in severe injury.

CAUTION

This signal term indicates a low risk, which, if not avoided, may result in minor or moderate injury.

NOTICE

This signal term warns you of potential damage.

Safety notes

This chapter contains general safety notes which you should always observe to protect yourself and third parties. Also observe the warning notes in each chapter of this user manual.

WARNING

Touching live parts can result in severe injury or death.

- Make sure that the correct voltage is present. You can find more information about this on the rating plate.
- Check the device regularly for damage.
Immediately disconnect the mains plug and do not operate the device if its housing, mains adapter or mains cord is defective or exhibits other visible damages.
- This device is disconnected from the grid by pulling the mains plug. Thus, make sure that the mains plug is always easily accessible.
- If the device emits smoke, smells burnt or produces unusual sounds, immediately disconnect it from the mains and do not operate it further.
- Never open the device housing. Repairs may only be carried out by an authorised specialist workshop. Only parts that match the original specifications may be used.
- Only use the accessory products specified by the manufacturer.
- Only use the device indoors.

- Do not operate the device in wet rooms and protect it from dripping and splashing water.
Make sure that no vases or other liquid-filled objects are located on or near the device in order to prevent liquid from penetrating the housing. If water or other debris ends up penetrating the housing, immediately pull the mains plug and, if applicable, take out any batteries. Then send the device to our service address.
- Never modify the device. Unauthorised modifications may affect the safety and functionality.
- Never touch the mains plug with wet hands.

WARNING

An unsuitable setup location may result in injury and damage.

- Never use the device unmounted in vehicles, in unstable locations, on wobbly tripods or furniture, on insufficiently dimensioned brackets etc. The speaker could tip or fall down and cause injury to persons or be damaged itself.
- Arrange the device so that it cannot be knocked over accidentally and make sure that the cables do not pose a tripping hazard.
- Do not place the device and the mains adapter near heat sources (e.g. heaters, ovens, other heat generating equipment such as amplifiers etc.).

- Do not use the device in environments where there is a risk of explosion.
- Only use the wireless function (Bluetooth®, wireless subwoofer) in locations where wireless radio transmission is allowed.

⚠ WARNING

Children can become trapped in the plastic wrapping when playing and suffocate.

- Do not allow children to play with the device or the plastic wrapping. There is a danger of suffocation.
- Never allow children to operate electrical equipment unsupervised.

⚠ WARNING

Swallowing a product battery may result in severe internal injury or even death.

- Store both new and used batteries so that they are not accessible to children.
- If it is no longer possible to safely close the battery compartment, stop using the remote control and store it so that it is not accessible for children.
- If you suspect that a battery has been swallowed or otherwise incorporated, promptly consult a physician.

⚠ CAUTION

Leaking battery acid may lead to chemical burns.

- Do not allow battery acid to come into contact with skin, eyes or mucous membranes. In the event of contact with acid, immediately flush the applicable areas with plenty of clean water and consult a physician if necessary.

⚠ CAUTION

Batteries (particularly lithium batteries) can explode if used improperly.

- Never attempt to recharge batteries.
- Only use batteries of the same or equivalent type.
- You must not heat or short circuit batteries and rechargeable batteries or dispose of them in fire.
- Do not expose batteries and rechargeable batteries to direct sunlight.

⚠ CAUTION

Extended listening at high volumes may lead to hearing loss.

To avoid damage to health, avoid extended listening at high volumes.

- When the volume is set high, always keep a certain distance from the device and never place your ears directly on the speaker.
- If your amplifier is set to full volume, it may produce very high sound pressure. This may have

psychological consequences and also cause physical injury. Children and pets are particularly at risk. Set your signal source device volume to a low setting before turning on the power.

 **CAUTION**

This product contains magnetic material.

- If necessary, consult your physician and ask for effects on implants such as pacemakers or defibrillators.

 **CAUTION**

Improper use may lead to damage or fire.



- Do not place open flames such as burning candles or similar on the device.
- Ensure sufficient ventilation.
- Do not place the device in direct sunlight.
- Only use the device indoors.
- Do not operate the device in wet rooms and protect it from dripping and splashing water. Make sure that no vases or other liquid-filled objects are located on or near the device in order to prevent liquid from penetrating the housing.

 **CAUTION**

The isolation pads can produce discolouration on sensitive surfaces.

- On parquet, varnished wood and similar surfaces, you should stick felt gliders to the rubber feet of the device or put a blanket under it. This will prevent discolouration of the floor over the long term.

Explanation of symbols

	Protection class II Dual insulation
	May only be used indoors
	Risk of electrical shock – do not open the housing. Disconnect the mains cord before changing a fuse.

Overview

Unpacking

- Carefully open the box and carefully lift the device out of the box.

CAUTION

Risk of injury/damage!

The red rubber loops on the back of the Cinebar LUX are just cord holders.

- Do not use the loops to carry the device!

Package contents

- (1) 1× Cinebar LUX
- (2) 1× remote control CB LUX RC
- (3) 1× mains cord
- (4) 2× AAA battery for the remote control
- (5) 1× allen key for opening the battery compartment of the remote control

Checking the package contents

- Check that all items have been delivered and that nothing is damaged.
- If the delivery is incomplete or exhibits damage from transport, please contact our service department (see Page 4).
- Do not in any case operate the device if it is damaged.

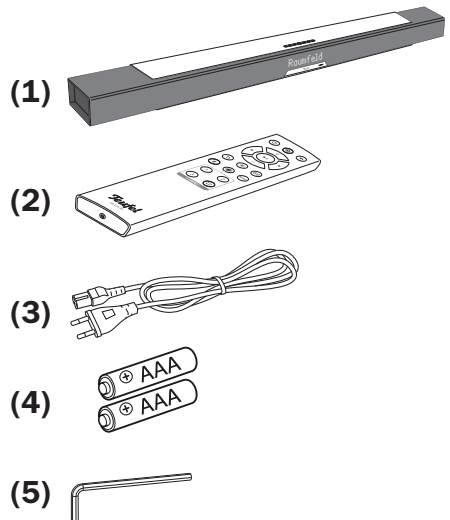

Controls And Connections

Back side

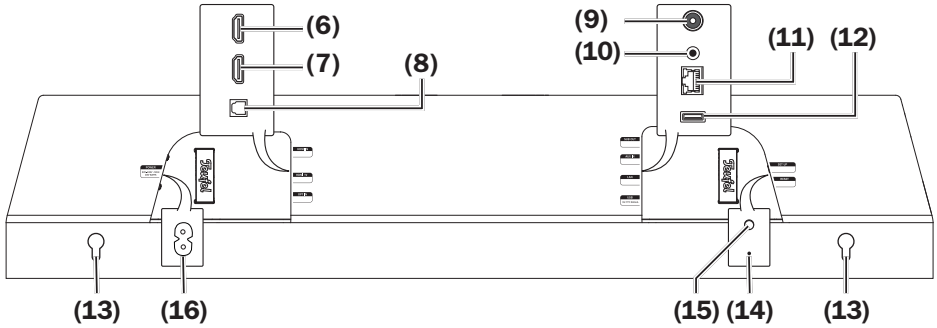

- (6)** HDMI IN – connection for an external HDMI device
- (7)** HDMI TV – HDMI connection for the TV set
- (8)** OPTICAL IN – input jack for optical-digital audio source device
- (9)** SUB OUT – output for the subwoofer
- (10)** AUX IN – input jack for analogue audio source device
- (11)** LAN – Network connector
- (12)** USB – USB port for loading external players and for software updates
- (13)** Keyhole openings for wall mounting
- (14)** RESET – push button to reset the device to the factory default settings
- (15)** SETUP – push Button to start Raumfeld setup
- (16)** POWER – connector jack for the mains cord **(3)**

Front side

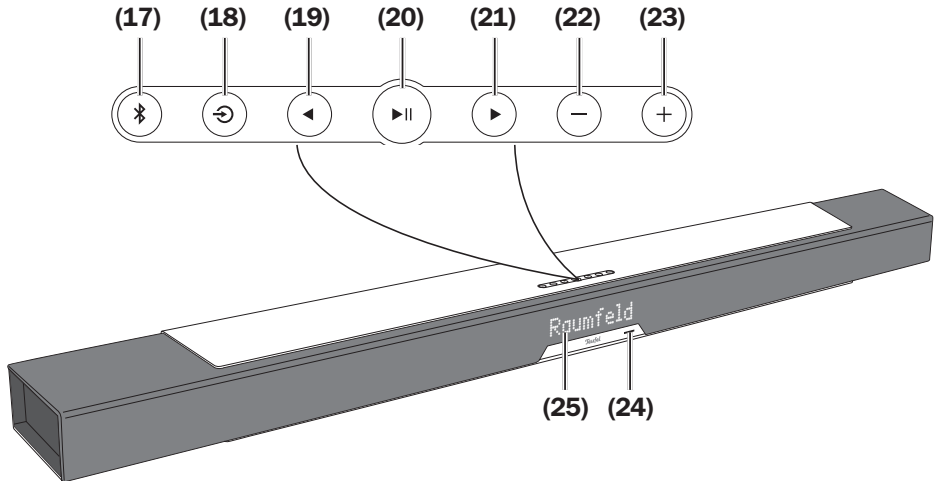

- (17)** ✖ – Short press select the Bluetooth® source and initiate auto reconnect.
Long press activates pairing.
- (18)** ↻ – select a source
- (19)** ▶ – control Bluetooth® device and Raumfeld: skip forward
- (20)** ▶|| – start/pause playback, switch the Cinebar LUX on and activate last source

- (21)** ◀ – control Bluetooth® device and Raumfeld: skip back
- (22)** – – reduce the volume
- (23)** + – increase the volume
- (24)** Indication LED
- (25)** Text field for the menu and information

Remote Control

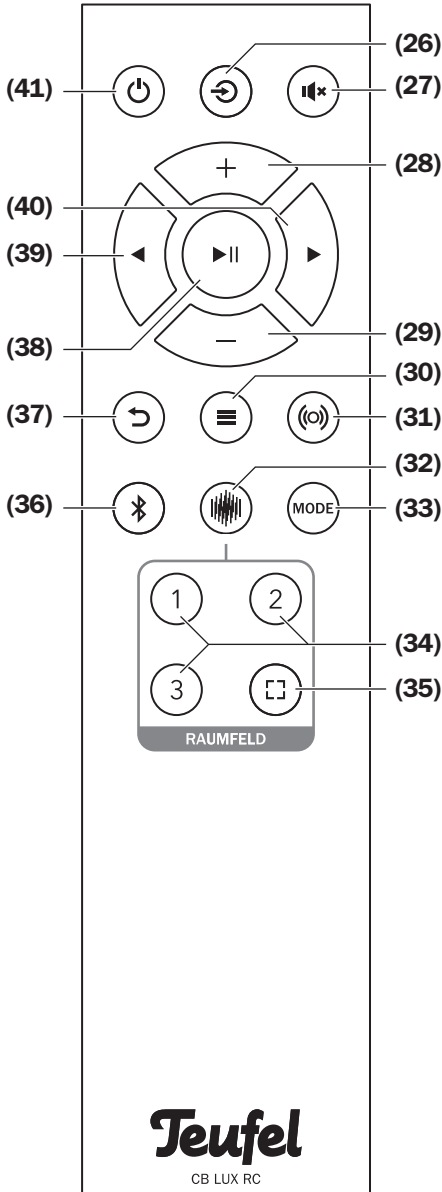

- (26)** – select a source
- (27)** – mute speaker
- (28)** **+** – increase the volume, navigate through the menu
- (29)** **-** – decrease the volume, navigate through the menu
- (30)** – access the menu
- (31)** – activate/deactivate DYNAMORE stereo widening
- (32)** – select Raumfeld source/play last Raumfeld source
- (33)** **MODE** – adjust the sound pattern: PURE (normal), VOICE, NIGHT (night mode)
- (34)** **1 2 3** – select/set Raumfeld favourites
- (35)** – function button, programmable via the Raumfeld app. Normal: Display information about spatial sound, sound pattern and system information
- (36)** – select the Bluetooth® source, start pairing
- (37)** – Back button
- (38)** – confirm menu, control Bluetooth® device and Raumfeld: start/pause playback, switch the Cinebar LUX on and activate last source
- (39)** – navigation button, control Bluetooth® device and Raumfeld: skip back
- (40)** – navigation button Control Bluetooth® device and Raumfeld: skip forward
- (41)** – switch the device on or to standby

⚠ CAUTION

Leaking battery acid may lead to chemical burns.

- Do not allow battery acid to come into contact with skin, eyes or mucous membranes. In the event of contact with acid, immediately flush the applicable areas with plenty of clean water and consult a physician if necessary.

Batteries (particularly lithium batteries) can explode if used improperly.

- Never attempt to recharge batteries.
- Only use batteries of the same or equivalent type.
- You must not heat or short circuit batteries and rechargeable batteries or dispose of them in fire.
- Do not expose batteries and rechargeable batteries to direct sunlight.

Inserting/changing the batteries

The remote control is powered by 2 type AAA batteries.

You should change the batteries if the remote control stops working properly or after 2 years at the latest:

1. To open the battery compartment, take the allen key **(5)** and carefully screw the lid off – it is slightly under tension from the springs.

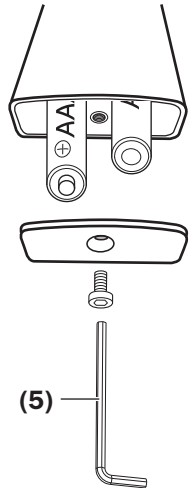

2. If applicable, remove the old batteries and dispose of them in an environmentally-friendly manner.
3. Slide the new batteries into the battery compartment according to the image on the back of the remote control.
4. Screw the lid back closed – it only fits the right way around and is slightly under tension from the springs.

Setup/Wall Mounting

NOTICE

If the device is subjected to warm temperatures after being cold (e.g. after transport), condensation may occur inside of it.

– *In this case, wait approx. 2 hours before you connect and activate it.*

The isolation pads can produce discolouration on sensitive surfaces.

– *On parquet, varnished wood and similar surfaces, you should stick felt gliders to the rubber feet of the device or put a blanket under it. This will prevent discolouration of the floor over the long term.*

Setup location

The space in front of or under the TV set is an ideal location.

Location tips

- Select a stable, level base.
In case of wall mounting, follow the instructions in the next chapter.
- Make sure that the environment is clean and free from dust.
- Select a location away from heat sources and direct sunlight.
- Do not place any heavy objects on the cables or the device.

Wall mounting

Proceed with care when mounting the Cinebar LUX on the wall and follow the instructions below.

You will need the following material to mount the product on a solid stone wall (not included in the package contents):

- 2 dowels (ø 6 mm)
- 2 screws, 4 x 55 mm, screw head ø 7–9 mm

⚠ CAUTION

Risk of injury/damage!

- Only qualified persons may mount the Cinebar LUX on the wall.
- The device may only be mounted on a suitable, solid wall. Special dowels or anchors may be necessary when mounting the product on lightweight walls. Consult a qualified professional in this case.
- Make sure that there are no cables or pipes in the drilling areas. Before you drill, use a metal detector to check the applicable areas. Otherwise, there is a risk of electric shock/short circuit!

1. Space the two keyhole openings **(13)** in the wall where you would like to mount the Cinebar LUX at a distance of 68 cm apart. Use a ruler, pencil and spirit level for this.
2. Use a metal detector to check the drill areas. If necessary, select another area for mounting.
3. Use an 6 mm rock drill to drill holes, which are approx. 50 mm deep, at the marked positions.
4. Insert 2 dowels (\varnothing 6 mm) all the way in the drill holes.

5. Screw one screw (4 x 55 mm) into each dowel until there is approx. 13-15 mm of space between the wall and the screw head.

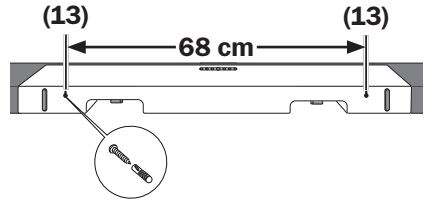

6. Press the Cinebar LUX up against the wall so that the screws vanish in the keyhole openings **(13)**.
7. Now pull the Cinebar LUX down so that the screws slip into the small slot.
8. If applicable, screw the screws further in or out until the Cinebar LUX is securely mounted on the wall.

Connecting

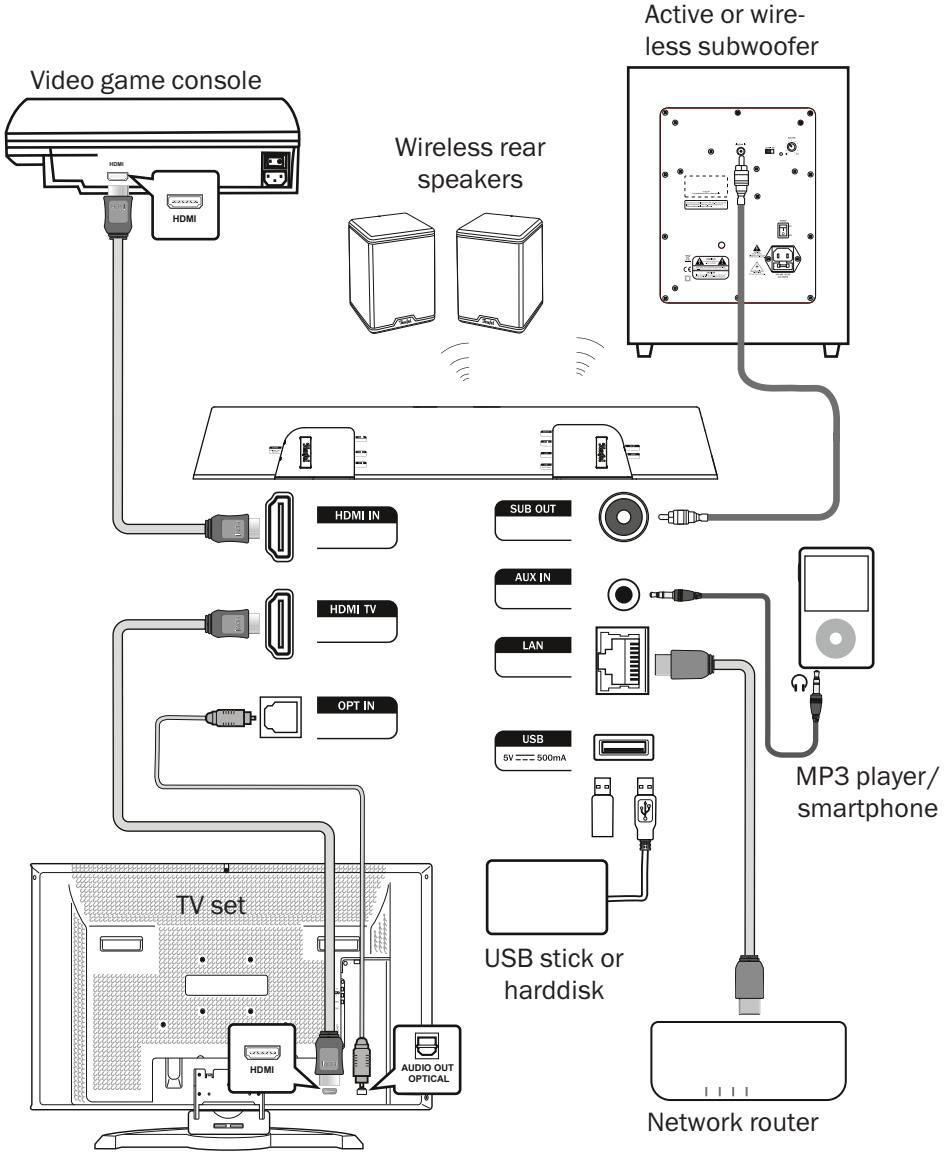

CAUTION

Risk of injury/damage!

- Lay the cables so that they do not pose a tripping hazard.

TV set

If your TV is equipped with an ARC capable HDMI jack, connect it via the HDMI TV jack **(7)**. You will need an ARC capable HDMI cable for this.

The ARC (audio return channel) HDMI function plays the television audio via HDMI. With some TV sets, this function must be activated in the menu and in most cases, only one HDMI connection is ARC capable (see the user manual for the TV set).

If your TV set does not support the ARC HDMI function, you can also connect it to the analogue AUX IN **(10)** or to the digital OPT IN **(8)** input depending on the configuration.

HDMI source

You can connect a source device with digital sound and picture to the HDMI IN jack **(6)** (e.g. a sat receiver, Blu ray player, game console).

You do not also have to connect this source device to your TV set. The video signal from these devices is looped through and forwarded to the television set via HDMI TV **(7)**.

Optical-digital source

You can connect the optical digital sound output of a source device to the OPT IN jack **(8)**. You will need an optical cable with a TOSLINK plug for this. Your source device requires either an optical 3.5 mm plug or also a TOSLINK plug.

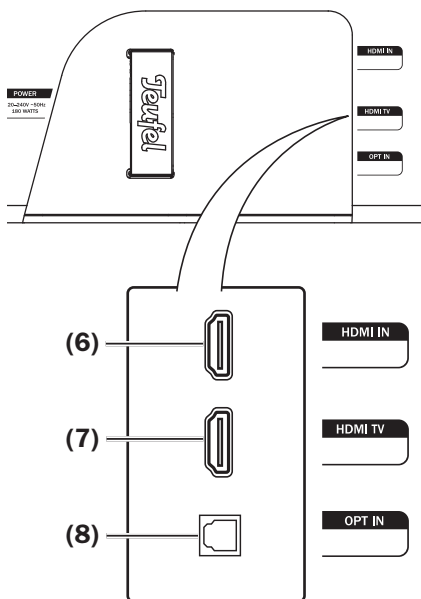

Analogue source

You can connect a source device with analogue sound (e.g. a CD player or TV set) to the AUX IN jack **(10)**.

You will need a stereo cable with a 3.5-mm jack plug to do so.

Subwoofer

You can connect an active subwoofer to the SUB OUT jack **(9)** using an RCA cable.

If you use an active subwoofer with a wireless connection, enable the connection in the “Speaker” menu (see page 26).

Network

To integrate Teufel Streaming into your network, you can use Wi-Fi or the LAN network connector **(11)**.

Connect the LAN jack **(11)** to your router.

USB

The USB jack **(12)** is used for playing audio files from an USB stick or harddisk (5V, 500 mA) via Raumfeld and for software updates (see page 32).

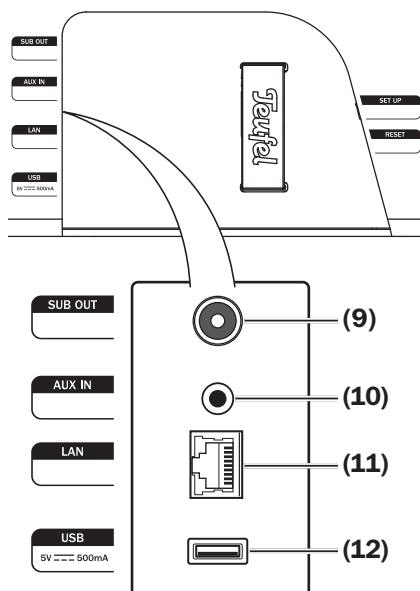

Rear speakers

If you use active speakers with a radio connection (e.g. “Effect”), enable the connection in the “speaker” menu (see page 25).

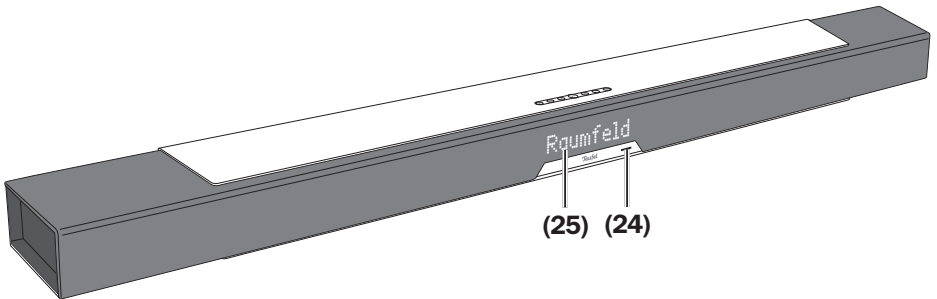
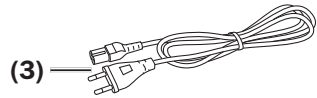
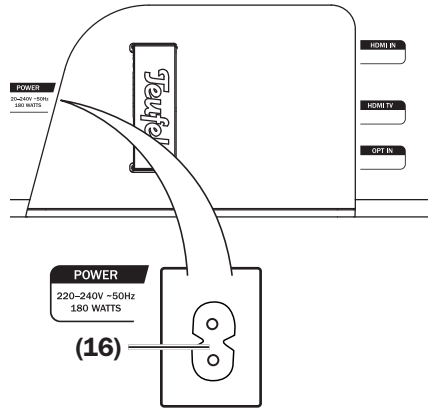

Power supply

1. Insert the small plug of the enclosed mains cord **(3)** in the POWER jack **(16)**.
2. Connect the mains cord with a mains socket.
The Indication LED **(24)** starts to pulse in white.





Operation

Activating and deactivating

- Turn the Cinebar LUX on or to standby with the  button (41).
- You can also turn the Cinebar LUX on by pushing any button on the device.
- By pushing the button  (20)/(38), you directly start playing back the last source.
- If the TV set connected via HDMI is compatible with HDMI-CEC, the Cinebar LUX will be activated via the TV set and – providing TV or HDMI IN is selected as the source – also switched off (standby).
- If the Cinebar LUX does not receive an audio signal for more than 20 minutes, it will automatically switch to standby (also see „Eco – Set Timer for Eco-Mode“ on page 27).

Selecting a source

- Select the source by pushing the  button (18)/(26) repeatedly.
- Use the  button (17)/(36) to select the digital Bluetooth® source directly.
- Use the  button (32) to select the Raumfeld Streaming source directly.

The selected source will appear in the text field (25).

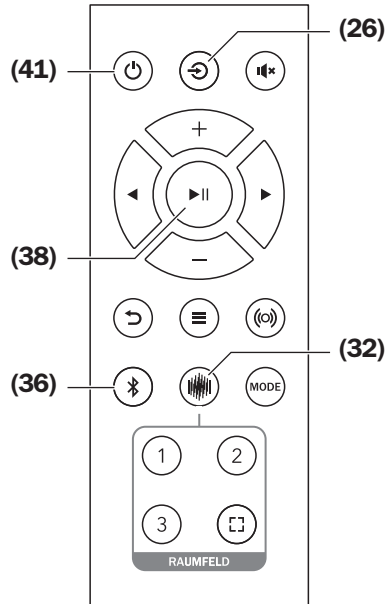
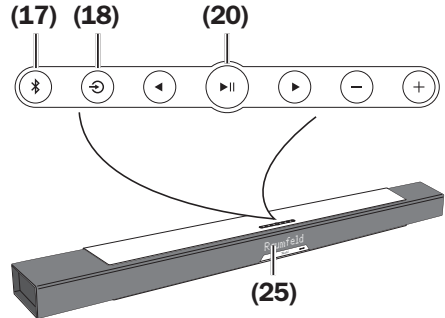

Adjusting the volume

- Push the **–** buttons (22)/(29) to decrease and the **+** buttons (23)/(28) to increase the volume. The current value will appear in the text field (25) while making the setting.
- In HDMI mode, the volume can also be adjusted with the remote control of the TV set (if HDMI CEC is supported by the TV set).

i The volume setting of an external player often affects the volume of the Cinebar LUX.

Adjusting the volume of the optional speakers

If you have connected a subwoofer or rear speakers, adjust the relative volume in the “Speaker” menu (see page 25).

Mute

- By pushing the button  (27) repeatedly, you can switch the sound off and back on.

Adjusting the sound

The sound is set in the “Sound” menu (see page 25).

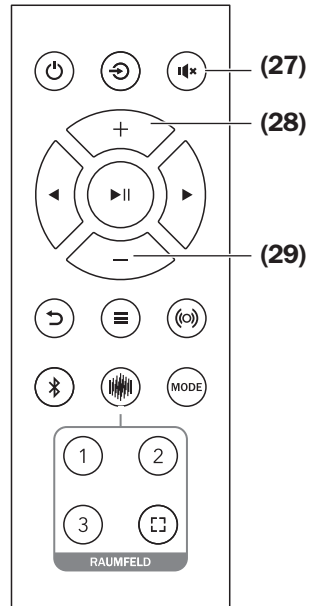
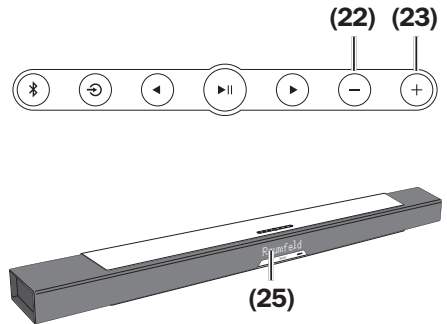

Equalizer

Push the MODE button **(33)** to select the three predefined sound patterns:

Pure (neutral)

Unchanged sound.

Voice

Clear sound for messages and magazines: Bass tones reduced, midtones raised.

NIGHT

Low frequencies and the overall level are weakened to avoid disrupting the sleep of uninvolved persons as much as possible.

Stereo widening

DYNAMORE® is a technique that makes the distance between the front speakers sound wider. This generates an impressive, spatial and wide-ranging sound.

- Use the  button (31) to switch stereo widening on and off.

Dolby Audio and Dolby mode

When playing back Dolby Audio or DTS encoded multi-channel tracks, the message “Dolby Audio” or “DTS” will light up in the text field **(25)** for three seconds.

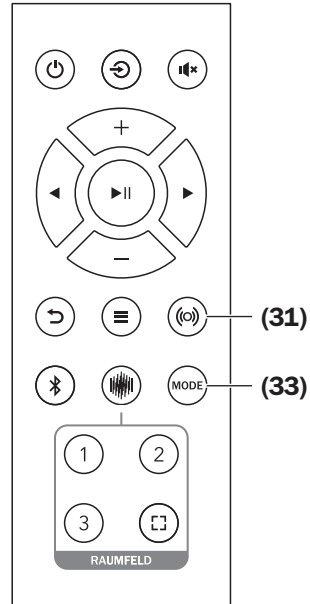

Menu

Use the menu to configure the functions of your Cinebar LUX. You can navigate through the menu with the remote control and it will be shown in the text field **(25)**.

To use the menu:

1. Push the button **≡ (30)**.
The first menu item “Sound” will appear in the text field **(25)**. You will see an arrow pointing to the right and one pointing down on the right edge: They show you where other menu items are.
2. Use the button **+** **(28)** and **-** **(29)** to select the desired sub-menu.
3. Open the sub-menu with the **▶** navigation button **(40)** or the **▶||** button **(38)**.
4. Use the buttons **+** **(28)** and **-** **(29)** to select the desired menu item and open it with the **▶** navigation button **(40)** or with the **▶||** button **(38)**.
5. Set the desired value with the buttons **+** **(28)** and **-** **(29)**.
6. With the button **↶ (37)**, you can access the previous menu or exit the menu.

The submenus are described below.

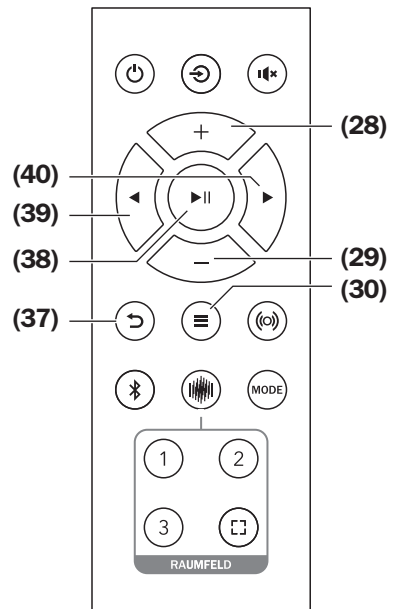
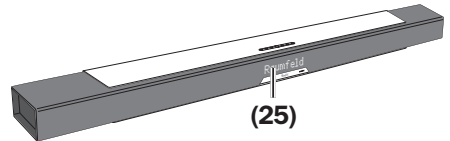

“Sound” menu

High/Mid/Bass

Here, you can set the high tones (High), the mid range tones (Mid) and the bass within a range from “-10 dB” (decrease) to “+10 dB” (increase).

Balance – Balancing rear channel levels

Use this item if you are using wireless rear speaker to set the volume level ration between the connected speakers.

DRC – Dynamic Range Control

With dynamic range control, quiet passages are amplified while the volume of loud passages is decreased. This can be helpful for audio books and when listening in loud surroundings. Possible settings: On, Off.

“Speaker” menu

SB – Soundbar settings

- Dist. – Soundbar Distance

Speakers located at different distances to the listening position may disturb the surround sound effect. To compensate these run time differences, you can specify the distance from the listening position to the speakers for all channels. The system calculates the required delays on this basis.

Set the distance between your listening position and the Cinebar LUX here: 0.3–12 m.

Rear

- Pairing

As soon as you choose this menu item, the Cinebar LUX searches for wireless rear speakers that are ready to pair. Start the pairing process on the rear speakers (see the user manual for the speakers).

- Stereo

With a pure stereo signal, the rear speakers remain silent. With this function, the system determines the required signals and generates complete surround sound. Possible settings: On (Enable), Off (Disable).

- Lvl L/Lvl R

Here, you can set the relative volume within a range from “-10 dB” (decrease) to “+10 dB” (increase) for each speaker.

We recommend that you use a sound level meter to optimally adjust the sound level.

- Dist. L/Dist. R

Set the distance between your listening position and the rear speakers here: 0.3–12 m.

Ext.Sub – External subwoofer

- Connec. – Connection Type of external Subwoofer

Here, you determine whether and how your subwoofer is connected to the Cinebar LUX:

Possible values: None, Wireless, Wired.

If you do not connect a subwoofer, select the setting “None” – thus, all sounds will be relayed to the stereo speakers.

- Pairing

When you chose “Wireless” as the connection Type (see above) the Pairing Menu Item appears in the Sub Menu:

As soon as you choose this menu item, the Cinebar LUX searches for a wireless subwoofer that is ready to pair. Start pairing on the subwoofer (see the user manual for the subwoofer).

- Lvl – Subwoofer Level

Here, you can set the relative volume within a range from “–10 dB” (decrease) to “+10 dB” (increase) for the subwoofer.

- Dist. – Subwoofer Distance

Here, you can set the distance between the listening position and the subwoofer.

- Phase

You can hereby switch the phase shift (180°) on and off for the subwoofer. Select the setting, with which the subwoofer produces the loudest and clearest sound.

LipSync – To synchronize audio and visual content

Digital image processing in the television set requires some time. To ensure that the picture and sound stay in sync, you can configure an audio delay here between 0 and 100 ms.

Calib. – Test tone for calibration

With this function, you can activate and deactivate noise as a neutral test tone and also set the speaker levels as described above.

“System” menu

Display

When operating the device, the text field **(25)** lights up to the value set under “Bright.” and dims back to the value set under “Fade” after a few seconds.

- Fade

Possible settings: Off, 10–100%

This value cannot be higher than the value for “Bright”.

- Bright.

Possible values: 10–100%

LED Br. – LED Brightness

Determines the brightness of the Indication LED **(24)** after initial setup using the app. Possible values: 0 (off) to 100 %

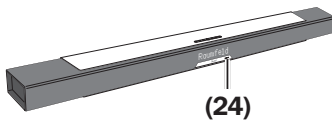

HDMI

- CEC

This option allows you to switch the HDMI function CEC on (Enable) and off (Disable).

With CEC, you can control the Cinebar LUX with the remote control of the TV set via the HDMI connection (activation and deactivation, adjustment of the volume, automatic switching between sources). For this, the TV set must support CEC.

AutoOn

If the Cinebar LUX is in standby, it will wake up as soon as a signal is recognised at an input.

Here, you can separately enable (On) or disable (Off) this function for the AUX IN and OPT IN inputs.

Eco – Set Timer for Eco-Mode

After a certain configurable period of inactivity, the Cinebar LUX will automatically switch to standby. Possible values: Off (never), 5, 15, 30 or 60 minutes.

Softw. – Software version

Based on the version shown here (e.g. “2.7.1”), you can determine whether new system software is available on our website

www.teufelaudio.com/software-updates.html (see page 32).

Info

Here you can see all the settings.

Reset

This clears all modified settings:

- Push the OK button (38).
The notice “Press decrease volume button (–) for 8 seconds to reset or hold (◀) to abort.” is shown in the text field.
- Push the navigation button ◀ (39) or the ↵ button (37) to cancel.
- Push and hold the volume down button – (29) for 8 seconds to reset.
The Cinebar LUX will restore the factory default settings. In the process, all wireless connections will be interrupted.

Spotify

Use your phone, tablet or computer as a remote control for Spotify.

Go to spotify.com/connect to learn how.

Setting up Raumfeld

- Make sure that your smartphone or tablet is registered in your home Wi-Fi.
- Have the Wi-Fi password for your router ready.
- Load the TEUFEL RAUMFELD APP from the Play Store/App Store.
- Once you have started the app, the setup wizard will guide you through the setup process.
- The SETUP button **(15)** is located on the bottom of the Cinebar LUX:

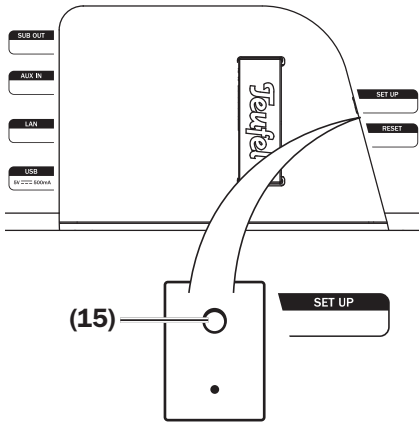

- You can find more information about setting up your Teufel streaming system at www.teufelaudio.com/service. The tips in chapter „Stereo widening“ on page 23 should also be helpful.

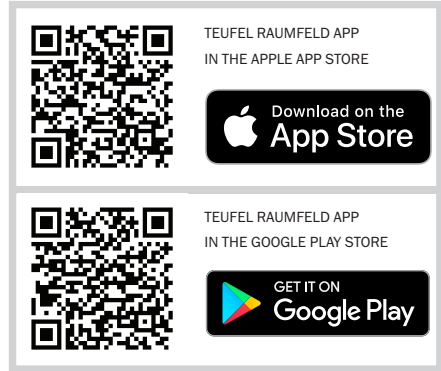

Integration of other devices in an existing Teufel streaming system:

- You do not have to set up the entire system again. You can use the app to add new devices (under “Settings”).

Bluetooth® Mode

Via Bluetooth®, you can establish a wireless connection between a compatible external player and the Cinebar LUX. The audio output of your external player is then emitted by the Cinebar LUX.

The Bluetooth® wireless transmission system has a range of approximately 10 metres that is limited by walls and furnishings. If the connection is cut off, the Cinebar LUX will attempt to re-establish a connection until you select another source.

NOTICE



- *Only use the Bluetooth® function in locations where wireless radio transmission is allowed.*
- *Please keep in mind that the Bluetooth® behaviour may differ depending on the external player's operating system.*

Bluetooth® options

Depending on the device type, your external player/smartphone may also have a menu for Bluetooth® options such as media playback. Here you can activate and deactivate the desired options. You can find more information about the Bluetooth® options in the user manual for your external player/smartphone.

Pairing and connecting

To play the audio of your external player on your Cinebar LUX via Bluetooth®, connect the devices with each other. This is called “Pairing”.

1. Turn on the Bluetooth® function on your external player (e.g. smartphone).
2. Use the  button **(17)/(36)** to select the “Bluetooth®” input on the Cinebar LUX.
3. Push the button  **(17)/(36)** again and hold it down for approx. 3 seconds to start the pairing process. The message “PAIRING” will appear in the text field.
4. Let your external player/smartphone scan for Bluetooth® devices. You will find more information about this in the user manual of your external player. After the search run, the “Teufel Cinebar Lux” should also be present in the list of detected devices.
5. Select “Teufel Cinebar Lux” from the list of detected devices.
6. If your external player asks for a code, enter “0000” (four zeros).

Pairing is now complete. “BT” appears in the text field and your Cinebar LUX will now act as a Bluetooth® playback device. The Cinebar LUX will now play back all sounds that would otherwise be

played by your external player/smart-phone.

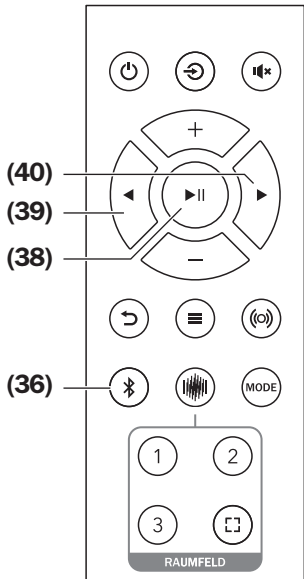
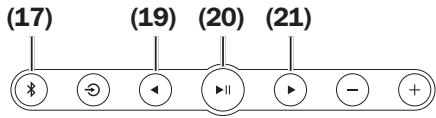

Playback

i The volume setting of the external player affects the volume of the Cinebar LUX.

1. Use the **Bluetooth** button **(17)/(36)** to select Bluetooth® as the source.
2. Turn on the Bluetooth® function on your source device.
3. Start playback on your source device.

You can control playback on your source device. You can also control some functions with the remote control of the Cinebar LUX:

- Pause playback:
Push the **OK/▶||** button **(20)/(38)**.
- Continue playback:
Push the **▶||** button **(20)/(38)** again.
- Play next track:
Tap the **▶** button **(21)/(40)**.
- Restart the current track:
Tap the **◀** button **(19)/(39)**.
- Play previous track: Tap the **◀** button **(19)/(39)** twice.
- If your source device is a smart-phone, the Bluetooth® connection will be interrupted in the event of an incoming call and you can make phone calls as usual. After finishing your phone call, the sounds will once again be diverted and played back by your Cinebar LUX.

Interruption of connection

If your external player moves out of the range of your Cinebar LUX, the Bluetooth® connection will be interrupted. If you are back within range within 120 seconds, the connection will be re-established automatically.

Terminating the connection

To terminate the Bluetooth® connection,

- deactivate the Bluetooth® function on your external player/smart-phone.
- select another source on the Cinebar LUX.

Software Update

The software of the Cinebar LUX is being continually developed.

NOTICE

Risk of damage!

– *The Cinebar LUX must not be turned off while a software update is being performed!*

Installing new software automatically

When you start the Teufel Raumfeld App, it searches for new software for your Teufel devices. If so, you can install the update with only one touch.

Installing Updates without a Connection to the Internet

If you operate your Teufel Streaming system without a connection to the internet you may install the updates via an USB stick.

1. Download the latest version:
<http://updates.raumfeld.com/raumfeld-updates.img>
2. Transfer the file raumfeld-updates.img onto a USB stick (FAT32 format).

3. Insert the USB flash drive into the Expand or host device (mostly the first device, which has been installed in your network or the Expand).
 4. Start the update on the Teufel Raumfeld App:
Settings > Devices > Updates
 5. After all updates have been downloaded, select “Install updates”.
 6. The Indication LED **(24)** flashes left/right during the installation process.
Once the update is complete, the Cinebar LUX will restart.
 7. Pull the USB stick out of the Expand or host device.
- The new software was installed.

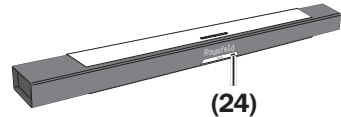

Care And Cleaning

NOTICE

External influences may damage or destroy the device.

- *If the device is to be left unattended for a prolonged period of time (e.g. during a vacation) or if a thunderstorm is forecast, pull the mains plug out of the socket. Otherwise, sudden overvoltage could cause the device to become defective.*
 - *In the event of prolonged absence, remove the batteries from the remote control. Leaked batteries may damage the remote control.*
 - *If possible, only use plain water without any additives. In case of stubborn marks, a mild soap solution may be used.*
 - *Do not use caustic cleaning products, white spirit, thinners, petrol or similar under any circumstances. Such cleaning agents may damage the delicate surface of the housing.*
- *Ideally, you should remove dust or small amounts of dirt with a dry, smooth leather cloth.*
 - *Use a damp cloth to rub off stubborn dirt. Make sure that no liquid penetrates the housing.*
 - *Then immediately wipe the damp surfaces off with a soft cloth without applying pressure.*

Troubleshooting

The following advice should help you to solve problems. If this does not help, you will find useful information in the detailed FAQs on our website. Otherwise, please contact our hotline (see page 4). Take note of the warranty instructions.

Problem	Possible cause	Solution
No function.	No power supply.	Check the function of the socket with another device.
The device doesn't emit any sound.	The wrong source has been selected.	Select the right source (page 21).
	The device is set to "mute".	Push the  (27) button or adjust the volume.
	The volume is set to "0".	Increase the volume.
	The volume of the external player has been set too low.	Carefully increase the volume of the external player.
No sound during TV playback	The ARC function on the TV is not activated.	Switch ARC on in the menu of the TV.
	HDMI jack on the TV does not support the ARC function.	Use the jack supporting the ARC function on the TV.
	HDMI cable without ARC function.	Use a suitable HDMI cable.
No sound with Bluetooth®.	No Bluetooth® connection.	Establish a connection (see page 30).
	Cinebar LUX has not been selected as the output device.	On the external player, select "Teufel Cinebar Lux" as the Bluetooth® output device.
	Bluetooth® connection impaired by another radio system (e.g. cordless telephone, Wi-Fi).	Set up the Cinebar LUX and/or external player in another location. Move to another room to test.

<p>The Raumfeld setup fails.</p>	<p>Restart your router and your smartphone or tablet. Set up the device near your router and switch any repeaters off for the duration of the setup process. If your router provides guest access, do not use it to connect your Teufel streaming devices.</p>
<p>The Raumfeld app is not connected or fails to locate the configured streaming devices.</p>	<p>Make sure that the Teufel streaming devices and the smart device are operated with the Teufel Raumfeld App on the same Wi-Fi. Restart your router. Briefly disconnect your Teufel streaming devices from the power supply and then start them again.</p>
<p>Music playback skips or is interrupted.</p>	<p>It is possible that one or more Teufel device(s) do not have a Wi-Fi signal or it is too weak. Place the devices closer to the router, try alternative setup locations or connect devices, which are set up far away, with an Ethernet cable. In the event of problems with multi-room systems with three or more devices, we recommend connecting at least one of the devices with an Ethernet cable and setting it as the host. As a test, refrain from using repeaters. If applicable, use an audio stream with low resolution. Also visit the website of the router manufacturer for tips on how to improve your Wi-Fi.</p>
<p>I would like to reset the device.</p>	<p>Notice: By resetting the device, all system configuration settings will also be reset. Resetting the device: When the device is switched on, use a paper clip that has been bent straight to push the RESET button (14) and hold it down until the device restarts (for at least 8 seconds).</p>

Wireless Subwoofer and/or rear speakers don't work.	The wireless subwoofer or rear speaker is off or doesn't have any power.	Switch the wireless subwoofer or rear speaker on. Check the mains cord and socket.
	No wireless connection.	Establish a connection (see "Pairing" on pages 25 and 26).).
	Wrong connection setting for the subwoofer.	Choose the right connection (see „Connec. – Connection Type of external Subwoofer“ on page 26).
The subwoofer hums.	The hum is due to line disturbance.	Buy a mains filter and connect both devices to it.
	The humming is caused by a multiple socket strip.	Use a different multiple socket strip or connect the subwoofer directly to the wall socket. It may also help to insert the mains plug in the socket the other way around.

Technical Data

Dimensions (W × H × D)	1140 × 130 × 69 mm
Weight	4.5 kg
Operating voltage	220-240 V~, 50 Hz, 180 W max.

You can find further technical data on our website. Technical changes reserved!

Declaration Of Conformity



Lautsprecher Teufel GmbH declares that this product complies with Directive 2014/53/EU. The full text of the EU Declaration of Conformity can be found at this web address:

www.teufel.de/konformitaetserklaerungen
www.teufelaudio.com/declaration-of-conformity

The following radio frequency bands and radio transmitting powers are used in this product:

Radio network	Frequency bands in MHz	Transmission power in mW/ dBm
Bluetooth®	2,402–2,480	2.5/4
Wireless system	2,405–2,477	1/0
WiFi/WLAN	2,412–2,472	40/16
	5,180–5,320	25/14
	5,500–5,700	25/14
	5,745–5,825	25/14

Disposal

Important information in accordance with the Electrical and Electronic Equipment Act (Germany: ElektroG)

We advise owners of electrical and electronic appliances that old electrical and electronic devices must be handed in separately from municipal waste, in accordance with the applicable regulations. Batteries and rechargeable batteries that are

not firmly enclosed in old electrical devices and lamps, and that can be removed from the old device without destroying them, must be separated from them in a non-destructive manner before they are handed to the collection point for their intended disposal. Please take note of our information on the Batteries Act [Germany: BattG] below for disposing of batteries.

You make an important contribution to returning, recycling and further processing of old devices if you sepa-

rate your old devices into the correct collection groups for recycling.

The symbol below of a crossed-out dustbin, applied to electrical and electronic appliances, also advises of the duty to separate collections:



Consumer electronics stores and supermarkets are obliged, under certain conditions, to take back old electrical and electronic devices, in accordance with section 17 of the Electrical and Electronic Equipment Act. Stationary retailers must take back an old electrical device of the same type when a new electrical device is bought (1:1 return). This also applies to home deliveries. These retailers must also take back up to three small old electrical devices ($\leq 25\text{cm}$) without this being linked to a new purchase (0:1 return). In accordance with the Electrical and Electronic Equipment Act, as online retailers of electrical devices and due to our product range, our obligation is limited to 1:1 return of large devices of $> 50\text{ cm}$ when selling a new electrical or electronic device of the same type. We comply with the obligation of return of devices other than large devices through our service provider. You can find the exact contact data and collection points on our website www.Teufel.de/entsorgung. It is also possible to return old electrical and

electronic appliances free of charge at an official delivery point run by the public waste disposal authorities.

Important: For safety reasons we ask that you refrain from sending lighting fixtures (some lamps). For return of lighting fixtures please use the public waste disposal collection points or contact us directly at www.Teufel.de/entsorgung.

As an end-user, you are responsible for deleting any personal data on old electrical appliances before handing it in.

Important: Our appliances can contain batteries/rechargeable batteries. If this is the case, please refer to its attached product documentation for additional information on the type and chemical make-up of the battery. For products with battery compartments you can directly remove the batteries or rechargeable batteries and dispose of them properly. If the batteries are built in to the product, do not in any case attempt to remove the batteries yourself, instead contact one of our employees or appropriate specialist staff.

Important information about the Batteries Act (Germany: BattG)

Batteries and rechargeable batteries must not be disposed of in household waste.

Old batteries can contain toxic substances that could damage the environment or your health if

not stored or disposed of properly. This applies especially to improper handling of batteries containing lithium.

However, batteries also contain important raw materials such as iron, zinc, manganese and nickel and these can be reused. Separate collection enables recycling of these raw materials and avoids any negative impact on the environment or human health due to toxic substances being released.



The crossed-out dustbin symbol means that you should not dispose of old batteries and rechargeable batteries in household waste. In addition, you, as the end-user, are legally obliged to return old batteries.

You can hand in batteries and rechargeable batteries free of charge at an official return point such as any public waste disposal collection point. You can also hand in old batteries, that we stock or have stocked as new batteries, at one of our Teufel stores or at one of our dispatch warehouses. However, if you send them to our dispatch warehouses we would like to point out the dangerous goods regulations of the dispatch provider you opt for and ask you not send batteries to us by post. You can get the addresses of our dispatch warehouses from our customer service.

Due to existing legal regulations, the battery manufacturer must use the following symbols with the following meanings when marking the batteries.

Hg: the battery contains more than 0.0005 mass percent of mercury

Pb: the battery contains more than 0.004 mass percent of lead

Cd: the battery contains more than 0.002 mass percent of cadmium

Otherwise, to avoid waste and littering, batteries with a long service life or rechargeable batteries should be used. Exchangeable rechargeable batteries enable long service for electrical and electronic appliances and thus devices and rechargeable batteries can be prepared for recycling (e.g. regenerating/exchanging rechargeable batteries).

Further information on preventing waste for consumers can, however, be found in the Federal waste prevention programme with the participation of the Federal states.

Teufel

Please contact our customer service department with any questions, suggestions, or complaints:

Lautsprecher Teufel GmbH
BIKINI Berlin, Budapester Straße 44
10787 Berlin (Germany)

www.teufelaudio.com

Phone: 00800 200 300 40 (toll-free)

Fax: +49 (0)30 - 300 930 930

Online-support:

www.teufelaudio.com/service

Contact:

www.teufelaudio.com/contact

No responsibility is assumed for the correctness of this information.
Technical changes, typographical errors and other errors reserved.