



Concept E 300 Digital

Teufel



Concept E 100 / 200 / 300 / 400

PC/multimedia/home cinema speaker systems
with integrated 5.1 amplifier

Teufel

For your information

The information in this document may be changed without advance notification and does not represent any obligation on the part of Lautsprecher Teufel GmbH.

No part of these operating instructions may be copied in any way, or transferred in any form, whether electronically, mechanically, as photocopies or recordings, without the prior written consent of Lautsprecher Teufel GmbH.

© Lautsprecher Teufel GmbH
Version 1.3
February 2010

Original packaging

We recommend keeping the packaging if you want to take advantage of the eight-week right to return as we can only accept the speakers IN THEIR ORIGINAL PACKAGING. We are unable to supply empty boxes!

Trademark

® All trademarks are the property of their respective owners.

Technical Data

Technical data can be found on our homepage at: www.teufelaudio.com

Warranty terms

12-year warranty for speakers and 2-year warranty for power amplifiers and electronics (from purchase date) on materials and work time, with the exception of damage caused by incorrect use or electrical or mechanical overload. An original copy of our invoice is required as the warranty document. This warranty is exclusively valid for speakers, power amplifiers and electronics that have been purchased from Teufel for private use by end customers. The warranty is not valid for speakers, power amplifiers and electronics that the end user has purchased from a different distributor. If the Teufel product is sold on privately, the warranty can be transferred to the purchaser, providing that the original proof of purchase is also transferred.

Contact

Please contact our service department if you have any questions, suggestions or if there is anything you think we could do better.

Lautsprecher Teufel GmbH

Gewerbehof Buelowbogen · Buelowstraße 66
10783 Berlin (Germany)
Ph.: 00800 200 300 40
Fax: +49 (30) -300 930 930
www.teufelaudio.com

Contents

Table of contents	Page 2
Safety information	Page 3
Introduction	Page 4
Unpacking • Contents • Assembly	Page 5
Accessories (optional)	Page 6
Set-up	
PC system	Page 7
Home cinema system	Page 8
Connection	
Satellites	Page 9
5.1 sound card	Page 10
DVD player/recorder · Decoderstation	Page 11
Stereo sources	Page 12
Operating elements on the subwoofer	Page 13
Start-up & Set-up	
DVD player · Decoderstation	Page 14
Troubleshooting	Page 15

Safety information

Please read the following safety information carefully.

In case of emergency
If any of the following occur, disconnect the appliance from the mains and consult our technicians:

- ▶ If either plug or cable is damaged
- ▶ If foreign bodies or liquid have entered the appliance
- ▶ If the device has been in direct contact with rain or other water
- ▶ If the appliance does not play, even though you have followed the operating instructions
- ▶ If the appliance has been dropped or damaged in some other way

We cannot accept any responsibility for incidents resulting from failure to observe the safety information.

Important: please read through these operating instructions very carefully. It is essential that you take note of all of the safety information and operating instructions before switching on the appliance. Please keep these operating instructions in a safe place for future reference.

Essential: please read the operating instructions. You should also follow all instructions for start-up and continued use.

Information on cleaning: please do not attempt to clean the device using household chemicals, as these could damage the surface. Simply use a dry cloth. Disconnect the appliance from the mains before cleaning.

Caution—moisture and sunlight: never operate the appliances in damp rooms, i.e. close to baths, showers, wash basins, drains, damp cellars or swimming pools; never use them where there is moisture. Never expose the speakers to high air humidity and avoid direct sunlight. Do not expose device to dripping or splashing water. Do not place objects filled with liquids, such as vases on the device.

Information on location: do not use the appliance unsecured in vehicles, in unstable locations, on wobbly tripods or furniture or supports that are too small. The speakers could fall and injure you or other people. The weight of the speakers could cause them to fall and cause damage, particularly if positioned on stands or on the TV/monitor, even if they have been positioned securely and stably. They could also fall as a result of external influences, such as the cable being pulled, by persons tripping over the cable or unintentional physical contact. This also applies to wall supports that have been attached inappropriately or incorrectly to walls that may not be capable of supporting their weight. Only use suitable wall brackets for mounting. Make sure that you know how much weight the walls can bear. The appliance must not be placed near sources of heat. This includes radiators and heaters, ovens and other appliances that emit heat (e.g. amplifiers). Sources of heat, such as fan heaters or candles, should not be placed on the speakers.

Ventilation: the slits and openings in the casing are provided for ventilation. Their purpose is to guarantee reliable operation and to prevent the appliance from overheating. These openings must not be blocked or covered, which includes placing the appliance on a bed, sofa, carpet or other soft surface. Do not place any newspapers or table cloths etc. on the appliance. The cooling plate of the amplifier electronics must not be covered or exposed to direct sunlight. Additional active cooling of the appliance is generally not permitted.

Electrical supply: the subwoofer should only be connected to a power source with the correct voltage as specified on the identification label. If you are unsure about the electricity supply in your home, please contact us or your electricity supplier for more information. The appliance does not need to be earthed. Please only use the appropriate two-core mains cable for connecting to the mains socket. This mains cable must not be modified under any circumstances. Regulations on polarity and earth connection must be observed. Use only an appropriate mains plug for connecting to the mains.

Information on wiring: please place the power cable flat and flush to the wall and floor. Loose cables constitute a risk as people could trip over them. This could also result in interference and cause the sound to be disrupted. The power supply cable should be laid so that it is not likely to be stepped on or squashed from the sides or above by heavy objects. Damaged cables must be replaced. Pay particular attention to the cable/plug connection, the mains socket and the cable output from the subwoofer. The power supply cable and the cables connecting the speakers should be checked regularly for insulation faults or breaks. If a fault is discovered, the appliance and the cabling must be disconnected from the mains immediately and the de-

fective cable must be replaced.

When not in use: disconnect the subwoofer from the power supply if the unit will not be used or you will not be home for extended periods.

During thunderstorms: in order to avoid damage caused by lightning strikes, switch off and unplug the device if you are expecting a thunderstorm.

Risk of overload: you should not overload wall sockets, extension cables or integrated appliance sockets, because this could potentially lead to short circuits and even fires. You should also avoid turning up the volume very high on the relevant amplifier, especially if you have increased the bass using the bass control, the volume button or one of the deep bass boost switches.

Foreign bodies and liquids: under no circumstances should foreign bodies and liquids be allowed to enter the appliance via any openings, as they could come into contact with parts carrying high voltages, which could then cause short circuits and fires. Therefore, do not spill any liquids of any kind on the device. Troubleshooting: do not attempt to repair the appliance yourself. Contact our service department first for authorisation, if you think that you can repair the fault yourself. Otherwise, the device must be sent to our service department.

Transport: the appliance should be transported using a hand truck. Great care must be taken during transport. Please note that uneven surfaces, sudden stopping or inappropriate exertion of force may cause the hand truck and the load to fall over.

Information on spare parts: Lautsprecher Teufel will provide you with spare parts during the warranty period. Your warranty will not be invalidated if you pick up the parts yourself from Lautsprecher Teufel.

Unusual sounds: if any unusual sounds occur during use or the sound becomes distorted, the speaker output must be reduced immediately so that the system plays an undistorted sound.

Connecting and changing the fuse: disconnect the mains plug. A faulty fuse should only be replaced with a fuse of the same type.

Information on volume: loud noise can damage hearing. Sudden high sound pressure may be created, particularly if a "subwoofer" in "Standby/Auto On" mode is switched on by a bass impulse at full volume. In addition to physical damage, please be aware of possible psychological consequences. Children and pets require particular care. If necessary, set the volume control of your signal source device to the lowest level. At high volumes, always keep a certain distance from the appliance and never have your ears right next to the speaker.

Dear Customer,

Thank you for purchasing the Concept E System.

With this speaker set from Teufel, you have chosen an elegant and powerful multimedia home entertainment system that, despite its compact dimensions, delivers excellent sound quality.

This speaker set can be operated either with a PC or DVD player with decoder. Stereo sources, such as MP3 players, satellite receivers, TV sets, games consoles, CD players or DJ mixers, can also be used very successfully with a Concept E set.

The Concept E 100/200/300/400 subwoofer has six integrated power amplifiers: one for the integrated bass speaker and five for the satellites. There is an analogue 5.1 input on the back for direct connection of compatible sound cards, DVD players or decoder boxes.

Because the set-up has a decisive impact on the sound characteristics of any surround system, we recommend that you take the time to position all of the speakers correctly. These operating instructions contain all of the information necessary for correctly setting up and operating our Concept E multimedia/home cinema set.

Please read these instructions carefully before operating the unit and store the manual in a safe place for future reference. We recommend keeping the packaging.



Please make a note of the serial number that can be found on a sticker on the box and the invoice number here:

My INVOICE NUMBER is:

.....

My SERIAL NUMBER is:

.....

The serial number and the invoice number make it easier for us to process your request quickly if you require service.

If you encounter difficulties during operation or if you think that there is something wrong with the appliance, please read the "Frequently asked questions" section on pages 15 and 16 carefully. You can find answers to the most frequently asked questions here.

Teufel

Unpacking • Contents • Assembly

First please check that all system components are included.

Unpacking

Fold back the flaps on the top of the box, remove the polystyrene packaging and carefully lift each loudspeaker out of the box.

All Concept E sets are supplied as a complete system.



▲ Subwoofer
CE 400 SW/CE 300 SW/CE 200 SW/CE 100 SW

Please note

Please keep the boxes for the eight-week return period at least, as we can ONLY repay the full purchase price if the products are returned in the ORIGINAL PACKAGING in which they were supplied!

Contents of Concept E 100/200

- ▶ 1 x subwoofer with integrated 5.1 amplifier
- ▶ 5 x identical satellite speakers
- ▶ 5 x table bases for satellite speakers
- ▶ Screws, for mounting speakers
- ▶ 25 rubber feet for the satellites
- ▶ 1 x IEC cable for power supply



◀ Satellite speaker
CE 10 FCR

Contents of Concept E 300/400

- ▶ 1 x subwoofer with integrated 5.1 amplifier
- ▶ 5 x identical satellite speakers
- ▶ 1 x cover for diagonal mounting of centre
- ▶ 5 x table bases for satellite speakers
- ▶ 1 x base for diagonal mounting of centre
- ▶ Screws, for mounting speakers
- ▶ 30 rubber feet for the satellites
- ▶ 1 x IEC cable for power supply



◀ Satellite speaker
CE 20 FCR



◀ IEC cables

Mounting the bases

If required, use the screws supplied to attach the satellite speakers CE 10 FCR or CE 20 FCR to the bases provided, as shown in the diagram. For acoustic reasons we do not recommend placing the satellites straight onto the table. We also recommend that you stick the rubber pads supplied to the points on the table bases provided for this purpose, to ensure a safe and secure position and to protect the top of the table as well as possible.

The M 50 P base or the Shortlock wall bracket, for example, are also available in our webshop. They provide a secure yet flexible way of displaying your satellites, as an alternative to the table bases supplied.



Optional accessories (selection)

Accessories

Because all customers have different requirements, Concept E systems are supplied without connecting cables, wall mounts or bases. We recommend the following articles:*

Teufel speaker cable 2 x 2.5 mm²

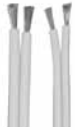

The highly flexible, unilaterally marked OFC cable has sufficient diameter to ensure unhindered bridging up to 15 meters. The white casing is inconspicuous, and is offered as a cable roll in two lengths: 15 or 30 meters.

Teufel Y adapter cable



For sound connections to PC or portable CD/MP3 players for amplifying the Concept E set. The 3.5 mm plug makes it easy to connect a sound card. You need one adapter for fully active operation on a PC in stereo and three for surround mode.

Teufel Base M 50 P



Slimline, height-adjustable base for the Concept E series. The speaker cables can be hidden inside the base.
Height: 80–120 cm.
Design: Metal, black or silver.

Shortlock wall bracket



This bracket makes it easy to mount the satellites using the thread in the speakers. The bracket allows free horizontal and vertical positioning.

* You can order the accessories shown online under:
www.teufelaudio.com

Teufel cable-packages for multimedia sets



We have complete cable packages which make it easy to connect the Concept E set to your source appliance.

There are a range of sets, with different types and lengths of cables.

AC 2005 WS

3 x stereo cinch → mini-jack cables for sound cards plus 20-metre speaker cable (0.75 mm²)

AC 3005 WS

3 x stereo cinch → mini-jack cables for sound cards plus 30-metre speaker cable (1.5 mm²)

AC 2015 WS

3 x stereo cinch cables for DVD player/Decoderstation plus 20-metre speaker cable (0.75 mm²)

AC 3015 WS

3 x stereo cinch cables for DVD player/Decoderstation plus 30-metre speaker cable (1.5 mm²)

Set-up: PC system

* Concept E 100/200/300/400

Because the satellite speakers are identical, you can position them any way you like and »designate« one of the five as the centre speaker.

* Concept E 300/400

We often recommend positioning the speakers in a diagonal set-up on a larger base, and using the cloth cover with the Teufel logo on the side (also supplied).

General information on arranging the speakers

Because of its compact size and elegant design, the Concept E 100/200/300/400 will beautifully integrate into your home. For a surround set, however, there are some set-up criteria you need to observe in order to get the best sound from your Teufel speakers.

The recommended set-up on the following pages represents the best possible arrangement for perfect multichannel playback at home. Your available space, your partner or your furniture may not always allow you to arrange the speakers in the ideal manner. Try to meet as many of the requirements as possible. Modern DVD players or the sound card software of a PC offer lots of opportunities to electronically compensate for any restrictions in the set-up. Generally speaking, the following rule always applies: you can always use our recommendations to experiment with what works best acoustically and optically. Let your ears (and eyes) decide!

Set-up as a PC system

If you are using the speaker with your PC it is advisable to focus on the sound requirements of the PC workplace, i.e. the area in which the screen and receivers are located.

Because the centre speaker transmits spoken dialogue, this speaker must be positioned as centrally as possible under/over/next to/on top of the monitor and inclined or angled towards the listener*. The front speakers are positioned, or wall-mounted, at equal distances to the right and left of the monitor/listening position. Attachment at ear height is optimal, but anything in the range between 0.80 and 1.60 metres is completely acceptable. If the values are outside the recommended range, you can slightly tilt the front speaker.

You can put the subwoofer anywhere you wish; it does not affect the other speakers. Often the best position is within the straight line created by the two front satellite speakers. The rear speakers should be behind or next to the listening position—ideally at the same height or higher (max. 2.10 metres). We do not recommend placing them lower.

Example arrangement of a Concept E set as a PC sound system

Non-optimum positioning due to different distances and heights can be offset by configuring the software for the sound card or decoder station.

Place the front and rear speakers in the grey area.

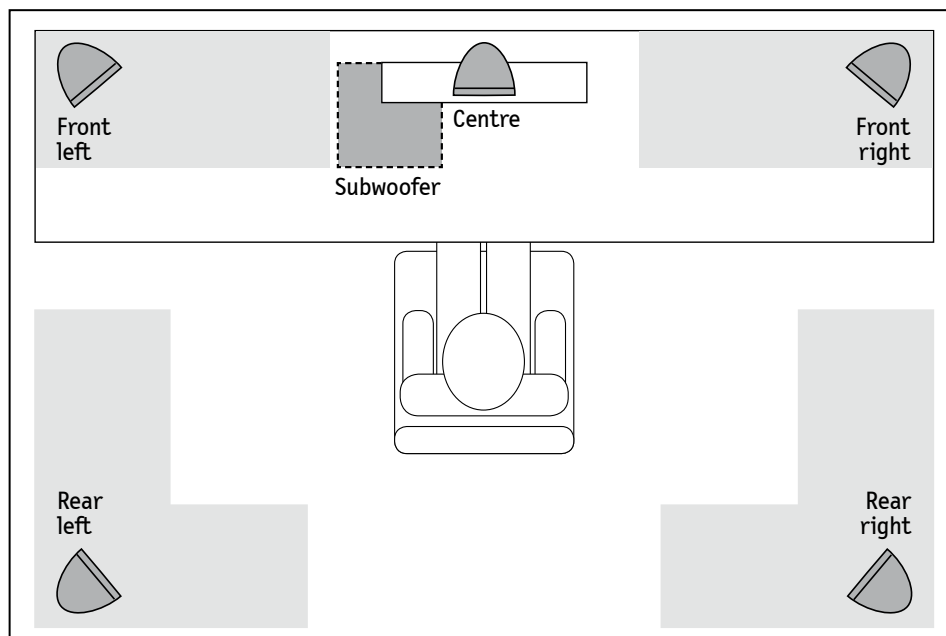

Set-up: Home cinema system

Setting up a home cinema system

When using the Teufel set as a home cinema system we recommended focussing on the section of the room where the TV and seats are positioned. It is useful to position the monitor as centrally as possible, from the perspective of the viewer/listener.

Because the centre plays back spoken dialogue, this speaker must be positioned as centrally as possible under or over the TV and inclined or angled towards the listener. You can use the base (supplied) for this purpose.

* The front speakers are set up in the traditional stereo position (distance to listener = distance between the left and right speaker), at the same distance, or wall-mounted, to the left and right of the TV. The »M 50 P« bases are ideal for this purpose, as are the »Shortlock« wall brackets. Using the base automatically guarantees optimum playback height for satellite speakers. The Shortlock brackets allow horizontal and vertical alignment to the listener.

The following applies to wall or shelf placement: the set-up heights should be between 40 centimetres and 1.20 metres. If you are unable to observe these distances, you can tilt the front speaker slightly towards the listener. It is important that the centre and main speakers are placed in an even arc, possibly slightly curved towards the TV.

You can put the subwoofer anywhere you wish; it does not affect the other speakers. The ideal position is within the straight line created by the two front satellites.

The two rear speakers should be set up to the left and right, either to the side or behind the listener – ideally at a height of no more than 2.10 metres, e.g. on a shelf or directly on the wall using the »Shortlock« wall mount. The speakers can be set up at the same height as the front speakers using the M 50 P bases; but we advise you not to locate them lower.

The optimum positioning is left and right from the listener (A) at around 20 degrees from the parallel. We recommend that the distance between the rear speakers and the listening location is more than 1.00 m. But if you (have to) sit closer, please ensure that the front of the speaker is not pointing directly at you but rather angle the speakers more towards the wall (B). Or create a greater distance by positioning the speakers higher than 1.20m (this can also be on the ceiling) or further away (C).

* Concept E 100 / 200 / 300 / 400

Because the satellite speakers are identical, you can position them any way you like and »designate« one of the five as the centre speaker.

* Concept E 300/400

We often recommend positioning the speakers in a diagonal set-up on a differently sized base, and using the cloth cover with the Teufel logo on the side, also supplied.

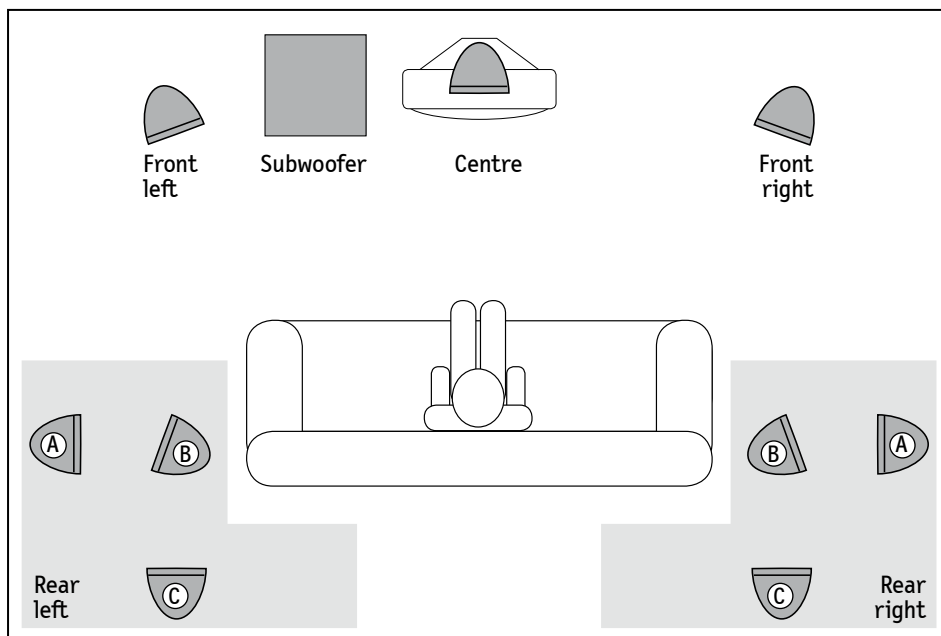

Example arrangement of Concept E for use as a home cinema

You can configure the settings on the speaker management system to compensate for non-optimum positioning due to differences in height and distance.

Please position the rear speakers within the grey area.

Connection: Satellites

Connecting the satellites

To do this, cut the cable to the required lengths. Strip the plastic coating from the ends of the speaker cables (as shown). The speakers and amplifier have corresponding [+] and [-] terminals. The [+] cable of the speaker cable is marked accordingly. It is important to observe the correct polarity when connecting the speakers: the plus pole of the speaker connects to the plus pole of the amplifier and the minus pole of the speaker to the minus pole of the amplifier. Connecting

the cables with the incorrect phases can result in thin sound, weak bass and reduced stereo characteristics. For multichannel surround systems, too, it is important that all speakers are connected with the correct polarity in order to ensure an appropriate three-dimensional atmosphere and the correct alignment of the sound.

Connect the speakers to the appropriately marked clamp connections on the rear of the subwoofer; i.e. the front-left speaker to FL and the rear-left speaker to RL, and so on.

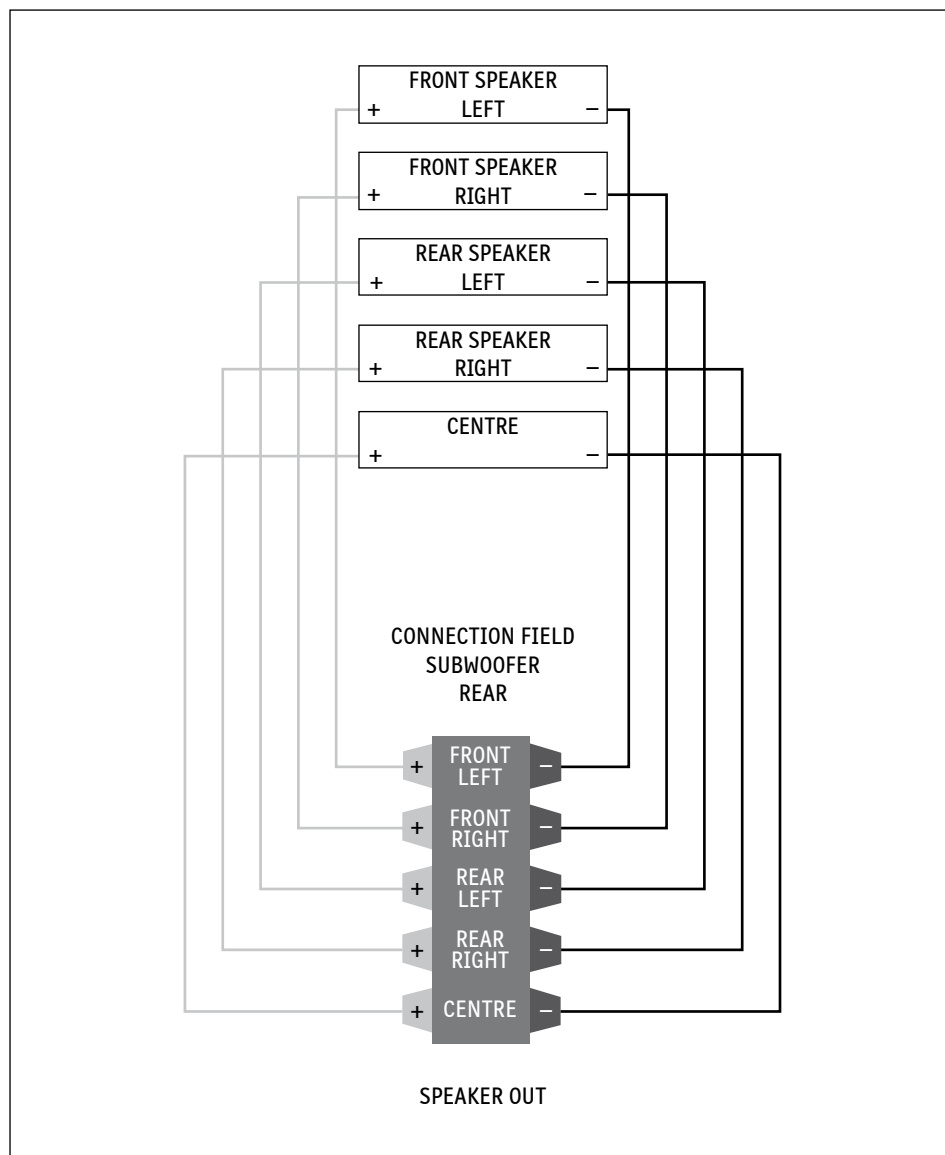

Connection: 5.1 sound card

Connecting to a 5.1 sound card

The Concept E 100/200/300/400 systems are perfect for using with any computer. If your sound card is set up for 5.1 operation, it will usually have three 3.5mm mini-jack outputs. Connect these to the inputs using three cables (3.5 mm stereo mini-jacks to 2 x cinch) for the front R/L, rear R/L, centre and subwoofer positioned on the back of the

Concept E subwoofer. The colours of the outputs and the types of signals transferred at each output differ from sound card to sound card.

Please refer to the sound card manual. The Teufel system then reproduces the surround signal decoded by the sound card.

5.1 SOUND CARD

SUBWOOFER CONCEPT E

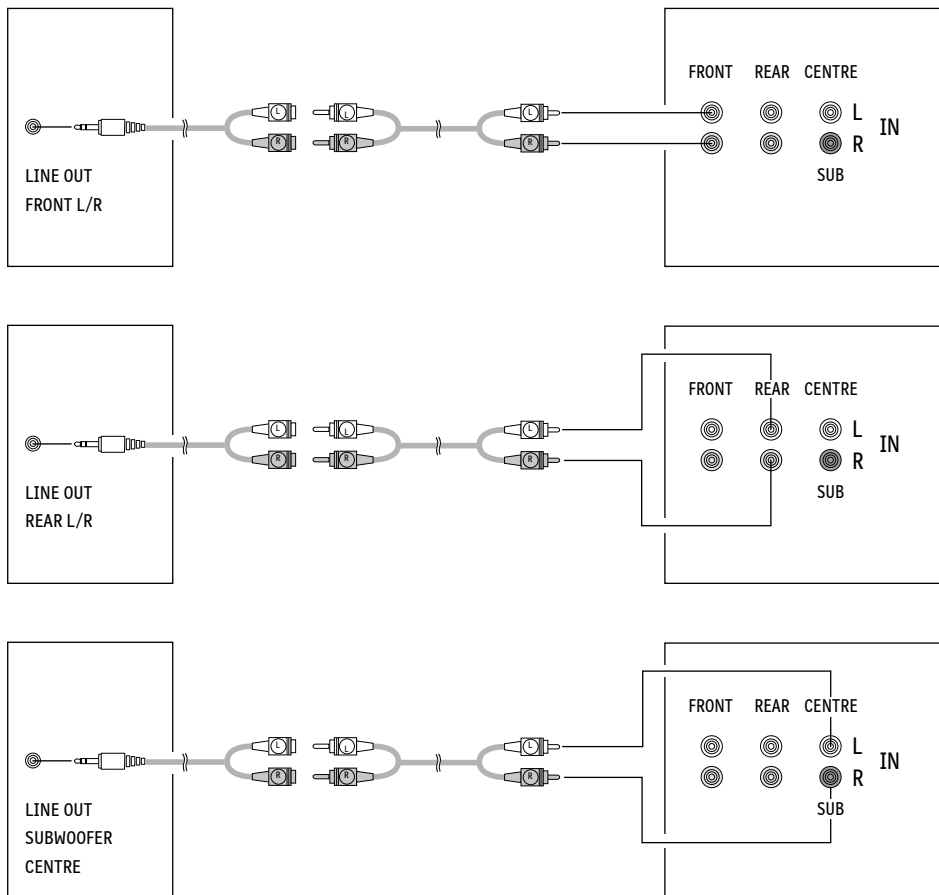

Example connection of a 5.1 sound card

Note

If you are using a 7.1 sound card, the outputs for the centre rear channels are not used.

Connection: DVD player/recorder · Decoderstation

Connection to a DVD player/recorder

As well as being connected directly to your PC, the Concept E 100/200/300/400 can also be connected straight to a DVD player/recorder. It allows you to create a complete home cinema sound system with just two audio appliances! To control the set directly via a DVD player, the player/recorder must have an integrated Dolby Digital/DTS decoder. This type of equipment can often be recognised by the fact that the DVD player has an analogue 5.1 cinch output at the back (6 cinch jacks for front R/L, rear R/L, cen-

tre and subwoofer). The DVD player/recorder is connected directly to the subwoofer with three stereo cinch cables, from the 5.1 cinch outputs of the DVD player to the 5.1 cinch inputs of the subwoofer.

Connecting the speakers to a Decoderstation

The speakers are connected to a Decoderstation in the same way as they are connected to a DVD player. Please refer to the Decoderstation manual.

DVD player settings are described in detail on page 15.

Connecting the Concept E to a DVD player/recorder without 5.1 analogue outputs

Even if your DVD player/recorder does not have a decoder or six analogue cinch outputs, you can still use the Concept E successfully.

Connect the stereo output of your appliance using a stereo cinch cable with the front input "In R/L" on the subwoofer.

The front loudspeakers are responsible for stereo signal reproduction. The centre generates an addition of the right and left channel of the stereo signal. The rear loudspeaker is responsible for the subtraction of the right and left stereo signal. This means that if the right and left signal are identical, the rear loudspeaker will reproduce little to no signal at all. The subwoofer transmits the bass signals from the left and right channel. This admittedly does not sound as perfect as Dolby Digital, but does sound better than pure stereo reproduction. You will also be able to use your speakers using a Teufel decoder later, allowing you to experience the pleasure of Dolby Digital and DTS.

DVD PLAYER/RECORDER

SUBWOOFER CONCEPT E

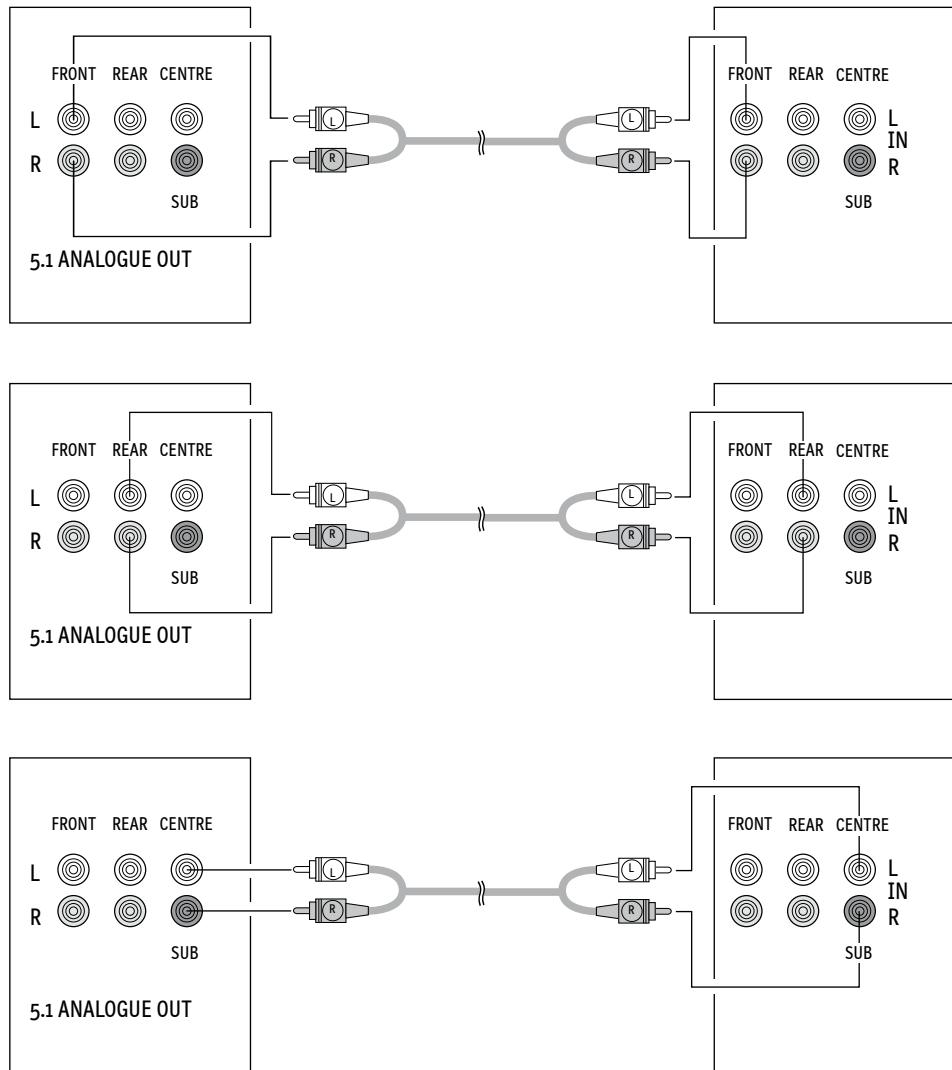

Connection: Stereo sources

Connection to stereo sources

Stereo sound card, notebook, MP3 player, satellite receiver, TV set, games console, CD player, DJ mixer, Discman, Walkman, etc ...

You can see just how versatile the Concept E series speakers are. The speaker system can be operated successfully with any of the above appliances. And not just in stereo, but also with virtual surround sound, using the integrated "upmix" function that involves all six of the Concept E speakers. This admittedly does not sound as perfect as Dolby Digital, but does sound better than pure stereo reproduction.

Here's how it works:

Connect the stereo output of your appliance to the front left/right inputs on the rear connector panel of the subwoofer. It is possible to use a 3.5mm mini-jack to stereo cinch adapter. All five satellite boxes are connected to the subwoofer via the speaker cable.

The amplifier now produces a mixed signal for all speakers. The front loudspeakers are responsible for stereo signal reproduction. The centre generates an addition of the right and left channel of the stereo signal. The rear loudspeaker is responsible for the subtraction of the right and left stereo signal. This means that if the right and left signal are identical, the rear loudspeaker will reproduce little to no signal at all. The subwoofer transmits the bass signals from the left and right channel.

NOTEBOOK
MP3 PLAYER
DISCMAN
WALKMAN
STEREO SOUND CARD

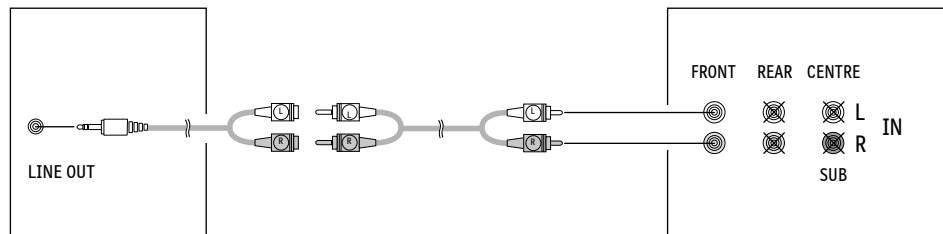

Notebook/laptop

For 5.1 reproduction you usually need an external sound card with six analogue outputs. Different companies offer solutions for connection to the PCMCIA port or via USB or FireWire. If your notebook already has three analogue mini-jack outputs, please proceed as described in the section »Connecting to a 5.1 sound card«.

Please note

There should be no more plugs in the other sockets on the subwoofer (in centre, subwoofer, rear R/L)!

SAT RECEIVER
TV
GAMES CONSOLE
CD PLAYER
DJ MIXER

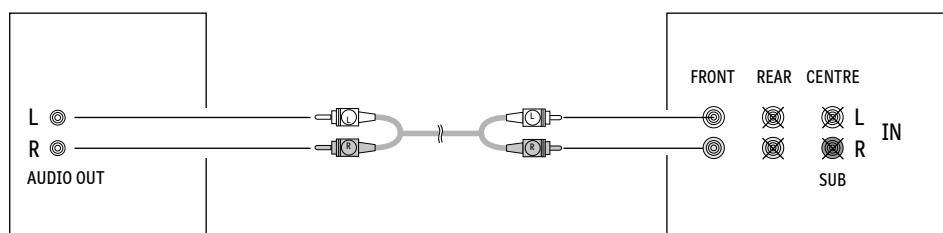

Please note

There should be no more plugs in the other sockets on the subwoofer (in centre, subwoofer, rear R/L)!

Operating elements: Subwoofer

Explanation of symbols



The arrow-headed lightning symbol in an equilateral triangle indicates the presence of a dangerous non-insulated electrical voltage within the system housing and therefore a risk of electrical shock.



The exclamation mark in an equilateral triangle, as affixed to the appliance, is to make the user aware of important operating and maintenance instructions.



This product complies with European Community guidelines 2004/108/EC and 2006/95/EC



The dustbin symbol printed on our products' type plates and amplifiers states that Lautsprecher Teufel guarantees proper disposal of these speakers and subwoofers in line with the Electrical and Electronic Appliance Act.



This product is a safety class II product in accordance with DIN standard EN 61140 (VDE 0140-1) and IEC 60417 and does not require a safety plug, only the plug supplied (2-pole). The casing has reinforced or double insulation against electric shock.

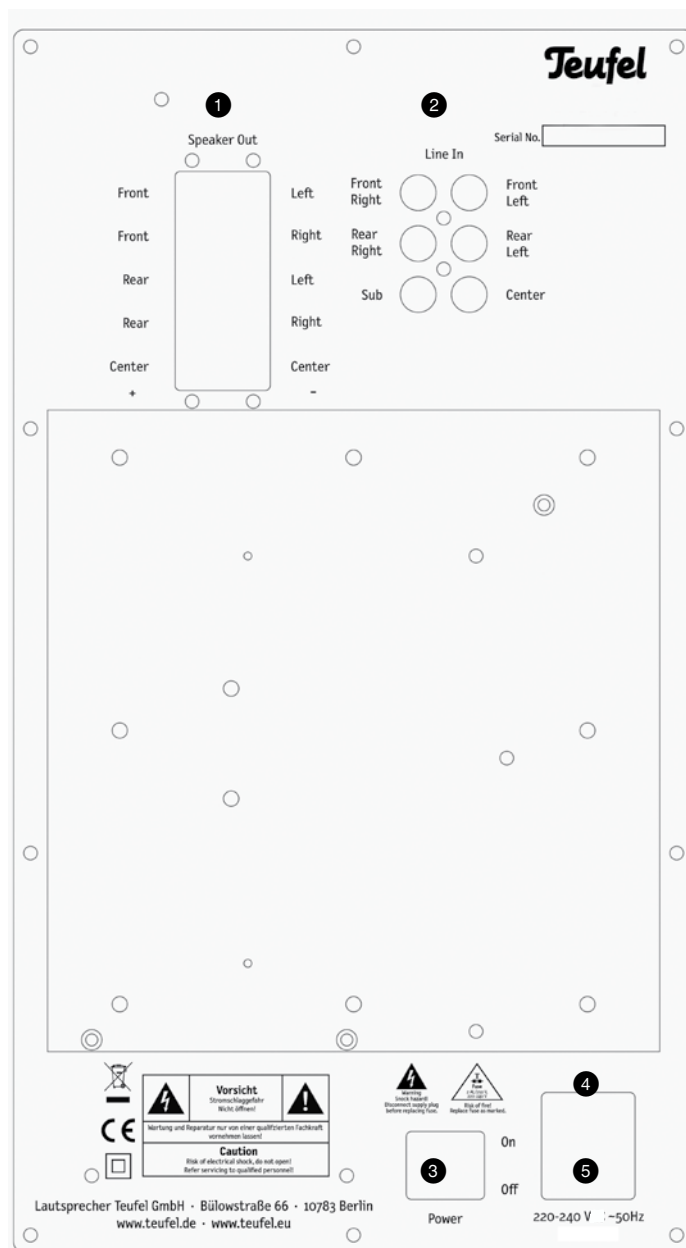

1 Speaker Out

Clamp the speaker cable from the five satellites here.

2 Line In

Connect the cinch cable from the playback device (sound card/DVD player/receiver) or control device (Decoderstation).

3 Power – power supply

When set to "OFF", the subwoofer is switched off, and on when it is set to "ON".

4 Cold appliance socket

The power cable is connected here.

5 Fuse

You can change the fuse here. The fuse should only be changed for one of equivalent type. You MUST disconnect the mains cable from the power supply before changing the fuse!

Attention:

The separating equipment of this equipment is the mains plug, this separating equipment must be usable without difficulties.

Start-up

Start-up

Switch the rear mains switch ③ to »On« to activate the 5.1 amplifier.



The ring encircling the round »Standby« button on the front of the woofer lights up »red«.

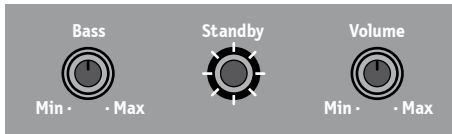

Press the »Standby« button to switch on the device fully – the rings encircling each of the three control elements turn »blue« indicating the subwoofer is now ready for use.

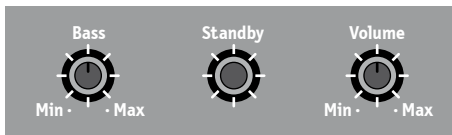

Volume

Turn the »Volume« dial to control the overall volume of the 5.1 amplifier.

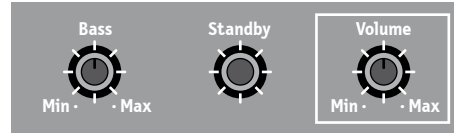

Please note that each of the upstream source devices, i.e. the sound card or DVD player, or the intermediary connection boxes like the decoder station itself, has its own volume control. You will have to find a balance between these devices and the Concept E system, which is an easy thing to do.

Bass volume

The Concept E subwoofer has a separate button for quickly and easily controlling the bass tones of the overall sound.*

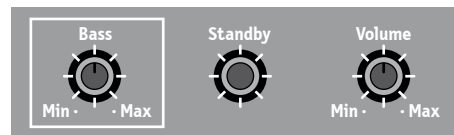

Please note

If you are going to be away or if the 5.1 amplifier is not going to be used for a long period of time turn the mains switch ③ to »Off«.

** The same applies here: each of the upstream source devices, i.e. the sound card or DVD player, or the intermediary connection boxes like the decoder station itself, has its own bass control. It is possible to find an individual balance between these devices. Feel free to experiment and find the configuration that works best for you.*

Set-up: DVD player · Decoderstation

Adjustment to the DVD player with 5.1 analogue output

The Concept E 100/200/300/400 set has no integrated decoder functions. Therefore it is »dependent« on the allocation of the external decoders when splitting the signals. This decoder is a component of the DVD player software. Its set-up options differ greatly from device to device. Please consult the handbook for your DVD player.



The following basic settings should always be made:

- ▶ Our front/centre/rear speakers should be defined in the speaker set-up menu (speaker management/bass management) of the DVD player as »small« or »normal« - not »large«!

- ▶ Set the subwoofer to »on« or »yes« on the speaker set-up menu.
- ▶ The optimum cut-off frequency is 150Hz – 120Hz or 200Hz is also possible.

Decoderstation settings

Please observe the detailed description in the Teufel Decoderstation manual or consult the support section on our website: www.teufelaudio.com.



The subwoofer is buzzing, what can I do?

These buzzing noises may be produced by connected devices or interference in the power supply.

Please perform the following test to help determine the cause of the buzzing.

1. Disconnect all cinch cables from the subwoofer's input jacks. If this eliminates the buzzing noise, please proceed to step B. Otherwise, start with step A.

A. Connect the subwoofer's power cable to a different power circuit (e.g. kitchen or bedroom).

If the subwoofer continues to buzz, please contact our support team.

If this action stops the buzzing noise, it means there is interference in your power supply. This may be caused by a dimmer switch or charging devices, for example. To determine the source of interference, please disconnect all electrical appliances from the mains power supply in succession. As soon as the buzzing noise disappears, you have found the source.

B. In this case, an "interference loop" is responsible for the fault. Please proceed as follows in order to ascertain the cause.

→ Disconnect the lead from your cable or satellite connection from the TV receiver and check whether the buzzing noise disappears. If so, use a sheath current filter for the cable connection to stop the loop, e.g. the coax AC 9022 ED sheath current filter. If you have satellite television, please connect the satellite receiver to the Decoderstation using an optical cable like Teufel's optical digital cable.

→ If this action fails to solve the problem, please contact us again so we can provide further individual assistance.

»There is no sound – neither from the satellites nor the subwoofer«

Please check to see if the LEDs on the front of the subwoofer display are illuminated; if not, change the fuse. The main fuse on the subwoofer might

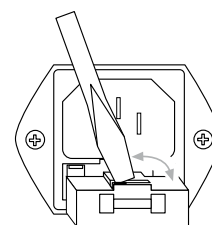

have blown as a result of a power surge. The fuse compartment on the Concept E subwoofer is underneath the IEC power connector (see illustration on page 13, item 5). Always disconnect the subwoofer from

the mains supply before replacing the fuse! Use a small screwdriver to open the lid, replace both fuses and return the fuse holder to the fuse compartment. The subwoofer should now be ready for use again.

»There is no sound from one of the satellites, or the sound is distorted – all of the other satellites are working«

In order to pinpoint the defect more specifically, please swap the non-functioning satellite for a functioning satellite in order to determine whether the defect is in the satellite or the subwoofer. If the non-functioning satellite now plays on a different subwoofer channel, the fault is probably with the subwoofer electronics. If the satellite fails to play on a different channel, the satellite itself is faulty.

»There is no sound from the subwoofer – all of the other satellites are working«

You can check the function of the subwoofer by connecting the subwoofer cinch input on the subwoofer only to the output from one of the front channels L/R front on the sound card or a device such as a portable CD player. If the woofer now plays, it could not have been getting the correct signal before. Either the cinch cable is faulty or the subwoofer output of your source device is not generating a signal. Alternatively, set the subwoofer volume to »Min«, remove the subwoofer cinch cable from the PC/DVD player/AV receiver, increase the volume carefully and touch the inner cinch thermistor with your finger. If you can hear buzzing or crackling, there is an error in the PC/DVD player/AV receiver or its settings. If the subwoofer stays silent, please read the following frequently asked questions carefully.

Troubleshooting

»The subwoofer does not work when connected to stereo sources, e.g. audio CDs (on PC/DVD player)«

The Concept E is purely a replay system – it does not have a built-in decoder function. Therefore it is »dependent« on the allocation of the external decoders when splitting the signals. This decoder is a component of the sound card, DVD player or decoder station software. If the signal only plays on two satellites in stereo mode, for example, the correct allocation in the software of the sound card/DVD/decoder station player is either not possible or not correctly set.

The Concept E is »not to blame« – it only plays back the signals it receives. Therefore, correct allocation in the software of the sound card/DVD player is essential. Please contact the support department of the sound card/DVD player manufacturer.

»There is a loud crack or noise when I switch the PC on or off.«

The speaker system reproduces any kind of acoustic signal that it receives from the signal source. It cannot differentiate between useful and disruptive signals. When the PC's sound card transfers the on/off impulses to the box set, the speakers will play it back. These will not usually damage your speakers. Nevertheless, we recommend minimising the volume via the PC's software before switching off, in order to limit these strong impulses.

»I'm receiving radio/interference signals«

In rare cases it may be possible to receive radio/interference frequencies; this depends on the local environment. Please remove all cinch cables from the subwoofer and check whether the interference still occurs. We recommend trying out shorter, higher quality, shielded cinch connection cables.

Basic function test

You can check the function of the subwoofer and the satellites by only connecting the (stereo) signal from an external source that is guaranteed to be good quality – such as a music CD played on a (portable) CD player – via a cinch cable (and possibly a Y adapter) with the front input L/R on the subwoofer.

The other four inputs on the subwoofer do not need to be occupied (= cinch cable disconnected). With this connection plug arrangement of front in L/R, the Concept E amplifier activates all satellites and the subwoofer through internal distribution.

If the subwoofer and all five satellites are now working when connected directly to a CD player, this means the Concept E was not receiving the correct signal before.

Either the cinch cable is defective (try exchanging it) or the output of your source appliance is not producing the correct signal.

If you continue to experience unwanted noise/individual malfunctions, there is possibly a defect in the Teufel system.

Teufel

Please contact our service department if you have any questions, suggestions or if there is anything you think we could do better.

Lautsprecher Teufel GmbH

Gewerbehof Buelowbogen · Buelowstraße 66
10783 Berlin · Germany

Ph.: 00800 200 300 40

Fax: +49(30) 300 930 930
www.teufelaudio.com

All information is provided without guarantee of correctness. Subject to technical changes, typing errors and mistakes.



Decoderstation 5

Teufel

For your information

The information in this document may be changed without advance notification and does not represent any obligation on the part of Lautsprecher Teufel GmbH.

No part of these operating instructions may be copied in any way, whether electronically, mechanically, using photocopies or recordings, or transferred without the prior written agreement of Lautsprecher Teufel GmbH.

© Lautsprecher Teufel GmbH
Version 1.2, May 2009

Trademarks

© All trademarks are the property of their respective owners.



Dolby

Manufactured under license from Dolby Laboratories.

"Dolby"; "Pro Logic" and the double-D symbol are trademarks of Dolby Laboratories.



DTS

Manufactured under license under U.S. Patent #'s: 5,451,942; 5,956,674; 5,974,380; 5,978,762; 6,487,535 & other U.S. and worldwide patents issued & pending. DTS and DTS Digital Surround are registered trademarks and the DTS logos and Symbol are trademarks of DTS, Inc.
©1996-2008 DTS, Inc. All Rights Reserved.

Original packaging

We recommend that you keep the packaging if you want to take advantage of your right to return goods within eight weeks, because we can only accept the Decoderstation 5 IN ITS ORIGINAL PACKAGING. We are unable to supply empty boxes!

Contact

Please contact our service department if you have any questions, suggestions or if there is anything you think we could do better:

Lautsprecher Teufel GmbH
Buelowstrasse 66
D-10783 Berlin (Germany)
Tel: +49 (0)30-30 09 300
Fax: +49 (0)30-30 09 30 30
www.teufel.eu

Technical data

Technical data can be found in the product description on our website at:
www.teufel.eu

Warranty terms

There is a two-year warranty on equipment and labour for electronics, starting from the date of purchase, with the exception of damage caused by incorrect use or electrical or mechanical overload. An original copy of our invoice is required as the warranty document. This warranty is only valid for electronics that was purchased from Teufel by end users for their own private use. The warranty is not valid for electronics that the end user has purchased from a different distributor. For third-party products, the warranty conditions of the respective manufacturers shall apply. If the Teufel product is sold on privately, the warranty may be transferred to the purchaser, providing that the original proof of purchase is also transferred.

Returns

Teufel grants customers the right to return or exchange goods within eight weeks of purchase, with reimbursement of the full purchase price paid. The return of individual components from a set is only possible if these components are also offered for sale separately by Lautsprecher Teufel. If one or more components are returned, any price discount given by Lautsprecher Teufel on all components in a set as part of the price for the set is waived. When returning a component, the customer will be reimbursed for the price difference between the set price and the purchase price of the individual components retained by him/her. The financial outcome for the customer is as if they had bought the remaining components at the individual price from the outset.

You can find more information on the subject of returns on the returns form that accompanies the delivery or online in the support area of our website, www.teufel.eu.

If you need to return an item, do not act without the prior agreement of Lautsprecher Teufel.

We can only process and accept returns if you have told us about the return by telephone first and discussed the procedure with us!

Contents

Table of contents	3
Instructions for safety and care	4
Welcome	5
Unpacking • Contents • Attachments	6
Introduction	7
Function	8
Front/Display Decoderstation 5	8
Back/Decoderstation 5	9
Remote control	10
Connection	12
Signal sources with digital and analogue outputs	13
Setting the Decoderstation 5	14
Menu structure	14
Overall volume and equalising the speakers	15
Input source, surround and speaker configuration and equalisation	16
Setting the delay	17
Setting the speaker size	18
Troubleshooting	19

Instructions for safety and care

Please read the following safety information carefully.

Risk of suffocation – keep packaging materials (e.g. the plastic bags and film) out of the reach and sight of children. Risk of electrocution – do not leave children unsupervised with electrical devices!

In case of emergency:

If any of the following occur, disconnect the appliance from the mains and consult our technicians:

- ▶ *If the plug or cable is damaged*
- ▶ *If foreign bodies or liquid have entered the appliance,*
 - ▶ *If the appliance has been in direct contact with rain or other water,*
- ▶ *If the appliance does not play, even if you have followed the instructions for use*
 - ▶ *If the appliance has been dropped or damaged in some other way.*

We cannot accept any responsibility for incidents that occur because safety information has not been adhered to.

Important: Please read through these operating instructions very carefully! It is essential that you take note of all of the safety information and operating instructions before switching on the appliance. Please keep these operating instructions in a safe place for future reference.

Essential: Please read the operating instructions. You should also follow all instructions for start-up and ongoing use

Caution – moisture and sunlight: Never operate the appliances in damp rooms, i.e. near baths, showers, wash basins, drains, in damp cellars or next to swimming pools. Never expose the device to high humidity and do not place it in direct sunlight. Do not expose device to dripping or splashing water. Do not place objects filled with liquids, such as vases on the device.

Information on location: Do not use the appliances unsecured in vehicles, in unstable places, on wobbly stands or furniture or supports that are too small. The speakers could fall down and injure people, including you. The appliance must not be placed near sources of heat. This includes radiators and heaters, ovens and other appliances that emit heat (e.g. amplifiers). Sources of heat may not be placed on the appliance e.g. fan heaters or candles.

Ventilation: Any slits and openings in the casing have been provided for ventilation. Their purpose is to guarantee reliable operation and to prevent the appliance from overheating. These openings must not be blocked or covered, including by placing the appliance on a bed, sofa, carpet or other soft surface. Do not place any newspapers or table cloths, etc. on the appliance. Additional active cooling of the appliance is generally not permitted.

Electrical supply: The appliance must only be supplied from a power source with the correct voltage, as specified on the identification label. If you are unsure about the electricity supply in your home, please contact us or your electricity supplier for more information. Only the mains adapter provided should be used for the electricity supply. This mains adapter must not be modified under any circumstances. Regulations on polarity and earth connection must be adhered to. Only use an appropriate mains plug for the mains cable.

Information on wiring: Please place the power cord flat and flush to the wall and floor. Cables that are laid loosely present a trip hazard. This could also result in interference and cause the sound to be disrupted. The electricity supply cable should be laid so that it is not likely to be stepped on or squashed from the sides or above by heavy objects. Damaged cables must be replaced. Pay particular attention to the cable/plug connection, the mains socket and the cable output from the subwoofer. If a fault is discovered, the appliance and the cabling must be disconnected from the mains immediately and the defective cable must be replaced. Remove the appliance's power supply cable from the socket for longer periods of absence or non-use.

Batteries: Be sure to insert the batteries with correct positive (+) and negative (-) polarities. Use batteries of the same type; never use different types of batteries together. If the

batteries leak remove them immediately and wipe away the liquid inside the battery compartment. Risk of explosion! Never throw batteries in a fire. Batteries must not be exposed to sun or heat.

During thunderstorms: In order to avoid damage caused by lightning strikes, the appliance should be switched off and also unplugged from the mains socket as soon as a thunderstorm is expected.

Risk of overload: You should not overload wall sockets, extension cables or integrated appliance sockets, because this could potentially lead to short circuits and even fires. Avoid turning up the volume control very high even when using a compatible amplifier.

Foreign bodies and liquids: Foreign bodies and liquids must not get into the appliance via its openings under any circumstances, as they could come into contact with parts carrying high voltages, which could then cause short circuits and fires. Therefore, do not spill any liquids of any kind on the device.

Troubleshooting: Do not attempt to repair the appliance yourself. Contact our service department first for authorisation, if you think that you can repair the fault yourself. Otherwise the appliance must be sent in for testing.

Unusual sounds: Any unusual sounds occur during use or the sound becomes distorted, the speaker output must be reduced immediately so that the system plays an undistorted sound.

Information on volume: Loud noises can damage hearing. Sudden high sound pressure may be created, particularly if a subwoofer in »Standby/Auto Onk mode is switched on by a bass impulse at full volume. In addition to physical damage, please be aware of possible psychological consequences. Children and pets require particular care. If necessary, set the volume control of your signal source device or amplifier to a low level. At high volumes, always keep a certain distance from the appliance and never have your ears right next to the speaker.

Care instructions and cleaning

To make sure you are able to enjoy your Lautsprecher Teufel product for a long time, please note the following tips:

- ▶ Do not expose the case to direct sunlight. Avoid extreme fluctuations in temperature and protect your speakers from moisture.
- ▶ Please only use a lightly dampened or dry cloth to clean the Decoderstation 5.
- ▶ Abrasive cleaners, products that contain alcohol and household chemicals should be avoided.
- ▶ Disconnect the appliance from the mains before cleaning.

Teufel Decoderstation 5



Dear Customer,

many thanks for buying the Decoderstation 5.

You have bought a very high quality decoder, because Teufel appliances are fitted with high quality components and have been carefully made.

Please read these instructions carefully before operating the unit and store the manual in a safe place for future reference. If you have any questions you can contact our engineers on +49(30)-300 9 300. You can also send us an e-mail using the contact form at www.teufel.eu. Please have your invoice number ready, so we can immediately locate your product and provide the best possible support.

Before contacting us with a question, please read these instructions carefully and visit our website at www.teufel.eu, where you can find the answers to many questions in the »FAQ/Support« area.

Please also refer to our safety information on page 4 of these operating instructions and only use the appliance once you have read the safety information.

Please take note of the serial number displayed on the sticker on the box (e.g. DE00509070122A-025) and this invoice number:

My INVOICE NUMBER is:

.....

My SERIAL NUMBER is:

.....

This serial number and the invoice number make it easier for us to process your request quickly if you require service.

Please make a note of your serial number and invoice number.

You can order the optional attachments shown directly from our online store: www.teufel.eu.

Unpacking

Fold the flaps on the top of the box outward, remove the rigid foam or polystyrene and carefully lift the appliance out of the box.

For your own benefit, we recommend that you do not dispose of the box as it can be used to guarantee safe transport if the device requires servicing later on.

Contents

- ▶ 1 x Decoderstation 5
- ▶ 1 x Infrared remote control
- ▶ 1 x Batteries for the remote control
- ▶ 1 x Mains adapter
- ▶ 1 x Operating instructions

Warning:

Explosion hazard with inappropriate replacement of the battery. Replacement only by the same or an equivalent type. Not expose batteries to excessively warm as sunshine, fire or like. If you plan to not use the device for a longer period of time: remove the batteries from remote control and store them appropriately to prevent possible damage from leaking.

Accessories (optional)



Mono-cinch cable

You can connect the Decoderstation 5 to a coaxial digital output using the mono cinch cable available from our online shop.



Optical fibre (Toslink)

You can connect the Decoderstation 5 to appliances with an optical digital output using the optical fibre cable available from our online shop.



Equalisation measuring device

The equalisation measuring device also available from our online shop allows the Decoderstation 5 to be precisely equalised. We advise using a gauge measuring device because you cannot achieve a similarly good result by equalising the levels by ear.



Teufel Y adapter cable

The first choice for sound connections from PC or portable CD or MP3 players to the Decoderstation 5. Connection to almost any sound card is ensured by using the thin plug on the 3,5mm jack. Available in 1,5 metre, 2,5 metre and 5 metre lengths.

About the Decoderstation 5

Decoderstation 5 is a stand-alone decoder that can be used to process audio signals from analogue and digital sources.

The appliance not only makes it possible to switch between various signals, it can also enhance stereo signal sources, for example, for a surround sound experience. The Decoderstation 5 is the perfect appliance for anybody who wants to operate a fully active speaker set without missing out on the comprehensive features that are otherwise only offered by AV-receivers.

The following signal sources can be connected to the Decoderstation 5:

Digital signal sources

The Decoderstation 5 can decode digital signals and reproduce them via the integrated analogue 5.1 multi-channel output. Digital sources such as DVD players that can transfer multi-channel digital sound tracks with the appropriate media (e.g. film DVDs) are especially well-suited to this type of connection. The digital signals are transmitted to the optical or coaxial connections of the Decoderstation 5.

Analogue signal sources

The Decoderstation 5 also offers ample connection options for analogue stereo sources. A total of three cinch stereo inputs are available for the same number of stereo signal sources. These two-channel stereo signals can be emitted with the Decoderstation 5 in various surround modes (configurations), for example in Dolby Pro-Logic II format encrypted in the stereo signal. This means that it is possible to reproduce all stereo sources effectively over several channels, either with or without the use of rear surround speakers.

Analogue 5.1 signal input

The Decoderstation 5 has an analogue 5.1 input. You can connect the appropriate signal sources, e.g. from a computer soundcard, here and forward them to the connected sound system.

Equalising the 5.1 speaker system

In addition, the comprehensive setting options of the Decoderstation 5 allow perfect equalisation of the speakers and therefore audio adjustment for your individual loudspeaker settings.

Function: Front / Display Decoderstation 5

Description of the display and operating elements on the front of the Decoderstation 5.



Switching on the Decoderstation 5

Switch on the Decoderstation 5 by pressing the dial control. The appliance will be ready for use after a few seconds. A progress bar will be shown in the display during this time.

Switching off the Decoderstation 5

Switch off the Decoderstation 5 by pressing the dial control for one second. Alternatively you can use the »Off« button on the remote control, which immediately switches off the appliance.

Standby

Soft blue illumination around the main dial indicates stand-by mode and that the Decoderstation 5 is ready to start up.

Display

The two-line display is your central information source about the status of the Decoderstation 5. All setting parameters are displayed here.



Note

Please note that the Decoderstation 5 display will automatically return to its default state after a few seconds if no input has been given.

Default display state

The left of the top line always shows the signal source selected: »5.1« for analogue multi-channel input, »OPT1« and »OPT2« (optical inputs), »COAX1« and »COAX2« (coaxial inputs) and »TV«, »CD« and »AUX« (analogue stereo inputs).

The overall volume is displayed in the form of a bar display to the right of this. The second line shows the surround configuration that is active at that time for the selected input.

More information on volume control and the sound configurations provided can be found on pages 15 and 16.

Operation from the appliance itself

You can control all of the Decoderstation 5 menu functions using the dial control, its push function, and the return button. An overview of the menu can be found on page 14.

① Dial control with push function

The dial control is used to select menu items, specific parameters, and to adjust values. It controls the overall volume of the system in its default setting.

The push function of the dial control performs several functions:

- ▶ Calling up the main menu from the default setting
- ▶ Confirmation of selection and access to submenu
- ▶ Exiting submenu/value input
- ▶ Confirmation of input - certain parameters, for example configuration of speaker size, require input confirmation in order to be accepted.

② Return

While you are descending the menu structure of the Decoderstation 5 using the push function of the dial control, the return button is used to navigate the next menu level up or to leave the entry field without entering any new values.

For example, if you are equalising an individual speaker, pressing Return once will take you to the next menu up and pressing it twice will take you to the main menu. Pressing Return several times lets you quit the menu input and the Decoderstation 5 will return to its default display state.

③ Mute

Pressing the button once will mute the Decoderstation 5. If you press it again the appliance will return to the level previously selected. The mute state is shown in the display of the Decoderstation 5.

Function: Back/Decoderstation 5



Description of the connections on the back of the Decoderstation 5 and their functions.

5.1 Channel Output (Pre Out)

A decoded analogue multi-channel sound signal is emitted via an analogue 5.1 output. Alternatively you can also use the outputs for the left and right front channels for reproduction in stereo. One cinch cable is required per channel to connect to an external appliance (e.g. a subwoofer with multi-channel input), that is a total of six mono cinch cables or three stereo cinch cables.

- ▶ Front left/right: Sound outputs of the left and right front channels
- ▶ Centre: Sound output of the centre channel
- ▶ Sub: Subwoofer output
(The subwoofer output reproduces the frequency area below 150Hz).
- ▶ Rear left/right: Sound outputs of the left and right surround channels.

5.1 In

The Decoderstation 5 has an analogue 5.1 input. You can connect the appropriate signal sources, e.g. from a professional computer soundcard, here and forward them to the connected sound system.

TV · CD · Aux · Stereo In

You can connect the stereo cinch cable (left / right) for connection to the analogue outputs of your stereo reproduction appliances (e.g. TV set, CD player, video recorder etc.) here.

Optical 1 · Optical 2 (Digital In)

For connecting the decoder with a digital signal source in optical format (Toslink). You can buy the cable required from the Lautsprecher Teufel on-line shop.

Coaxial 1 · Coaxial 2 (Digital In)

For connecting the decoder with a digital signal source in coaxial format (cinch).

+ 12 V

DC in power supply from included AC wall adapter.

Note

You will need an extra phono pre-amplifier to connect a record player.

Function: Remote control



With the included remote control you can fully control all of the Decoderstation 5 settings from the comfort of your sofa.

Standby

Activate the Decoderstation 5 using the standby button of the remote control. Switches the device to active operation (press once) or back into standby mode (by pressing again). You can always tell if the device is ready for operation because the background of the dial control will light up.

Mute

Pressing the button once will mute the Decoderstation 5. If you press it again the appliance will return to the level previously selected. The mute status is shown in the display of the Decoderstation 5.

You can select the required input using the selection buttons on the remote control.

5-1

Direct selection of the analogue 5:1 signal input on the back of the decoder as input source.

Optical 1 - 2

These buttons select one of the two optical digital inputs on the back of the decoder as input source.

Coax 1 - 2

These buttons select one of the two coaxial digital inputs on the back of the decoder as input source.

TV - CD - Aux

Each of these buttons select one of the three analogue stereo inputs on the back of the decoder as input source.

Display

Pressing this button once switches the LC display off. Pressing the button again switches the LC display back on.

Return

Pressing the return button once will end the current screen menu or return to the default display state.

Function: Remote control

Mode

You can select the various surround configurations of the Decoderstation 5 by repeatedly pressing this button.

Speaker

You can select the various speaker configurations of the Decoderstation 5 by repeatedly pressing this button.

Test

After this button has been pressed, the Decoderstation 5 produces test signals for equalising the speakers. The test signal is then emitted from each loudspeaker in turn (see p. 15 – equalising the speakers).

Volume +/- (speaker symbols)

You can use these two buttons to increase or reduce the overall volume of the Decoderstation 5 or the individual speaker levels. The current setting is shown in the LC display.

Left/right arrow

Pressing these buttons triggers the same functions as rotating the control wheel on the Decoderstation 5.

OK

Pressing this button triggers the same functions as pressing the dial control on the Decoderstation 5 (push function).

Front L.

This button leads straight back to the volume control of the left front speaker.

Front R.

This button leads straight back to the volume control of the right front speaker.

Centre

This button leads straight back to the volume control of the centre speaker.

Side L.

This button leads straight back to the volume control of the left surround speaker.

Side R.

This button leads straight back to the volume control of the right surround speaker.

Subwoofer

This button leads straight back to the volume control of the subwoofer.

Inserting or changing the batteries.

Please change the batteries if the remote control stops working even when right next to the Decoderstation 5.

Please note:

- Do not combine new and old batteries
- Do not use different types of batteries
- Observe polarity and the markings in the battery compartment

Note

You can reproduce all of the functions of the dial control using the OK button and both arrow buttons, left and right.

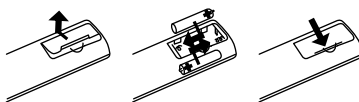

Connection

Example allocation of inputs and outputs of the Decoderstation 5

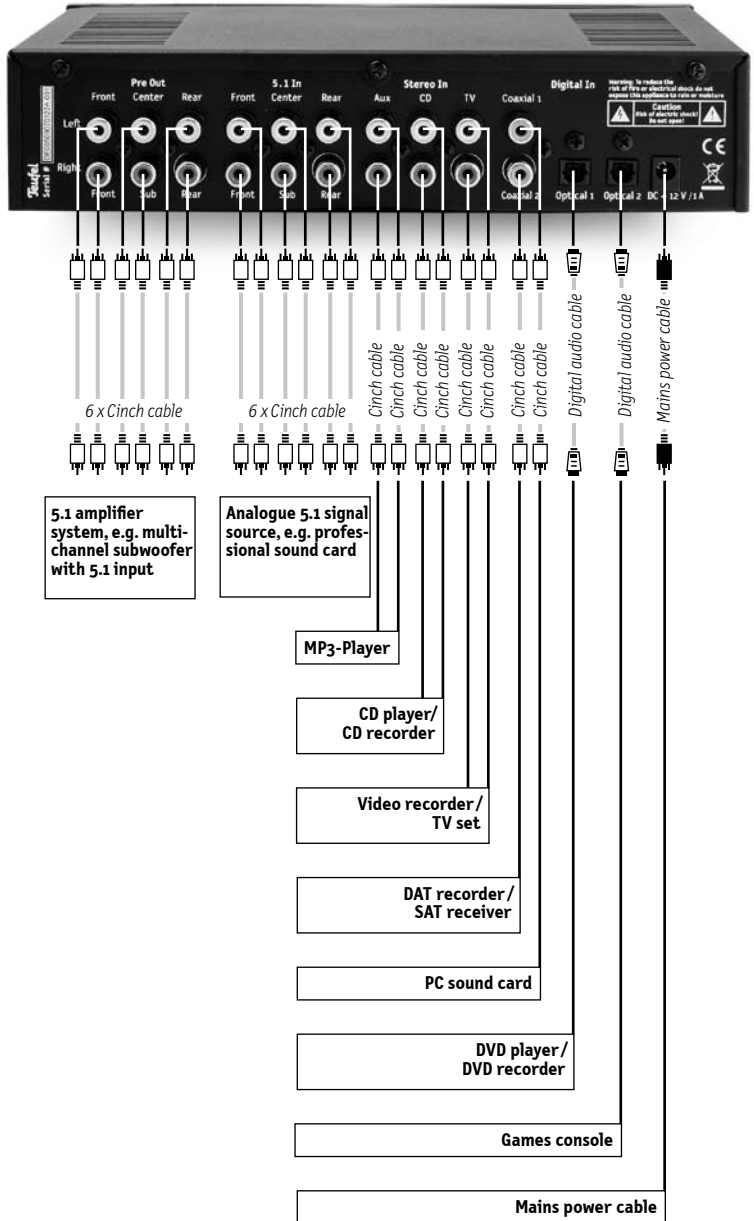

Connection

The Decoderstation 5 is perfect for combining digital and analogue signal sources. With four digital and three analogue inputs and an analogue 5.1 signal input it offers connections for numerous signal sources.

Connecting digital signal sources

The Decoderstation 5 automatically recognises the signal format transferred via the digital inputs, decodes the data flow and changes it into a stereo or multi-channel signal.

Connection to one of the two optical digital inputs

E.g. sound card with digital output, CD player, DVD player/recorder and sat receiver etc.

Use an optical digital cable (Toslink) to connect appliances with optical digital output.

Before connecting the optical digital cable, remove the protective caps from the fibre optics and connection jacks. You can obtain the optical cable required from the Teufel online shop.

Connection to one of the two coaxial digital inputs

E.g. sound card with digital output, DVD player/recorder, sat receiver and games console etc.

Use a cinch cable for connecting appliances with coaxial digital output.

Connection of signal sources with analogue outputs.

In addition to the digital inputs, the Decoderstation 5 also has three analogue stereo inputs.

They can be assigned to analogue appliances of your choice, for example, a stereo sound card, an MP3 player, a TV set, CD player, or video recorder etc.

Either a stereo cinch cable or a 3.5mm mini-jack-Y adapter cable is required per appliance (e.g. for connecting to an MP3 player).

Connecting an analogue 5.1 signal source e.g. multi-channel computer sound card, etc.

The 5.1 input of the Decoderstation 5 is used for connecting external, analogue 5.1 signal sources, such as a professional sound card or a DVD player with analogue outputs. One cinch cable is required per channel for connection, i.e. a total of six mono cinch cables or three stereo cinch cables.

Using the 5.1 input as a 4th stereo input

If you require an extra (fourth) stereo input, you can use the 5.1 input for that. Connect your analogue signal source, for example a cassette recorder, to the Front Left and Front Right inputs.

When connecting the devices, please note the relevant information in the handbooks for the components used.

Note

The 5.1 input is not influenced by the surround-specific parameters of the Decoderstation 5. Except for changing the overall volume, the signal connected here is only forwarded from the input to the output of the Decoderstation 5.

Select the sound setting »5.1 Direct«.

The other settings relate to the Front Left and Front Right inputs, i.e. to operation as a 4th stereo input.

Setting-up the Decoderstation 5

Menu structure

You can access the default display settings in the main menu by pressing the push button of the dial control once.

You can find more specific information on navigation within the menu structure on page 8.



Note

The display shows arrows during selection. If you follow these arrows, further choices will be made available.

* The availability of these entries depends on the surround and speaker configurations selected.

** The availability of the subwoofer entry depends on the speaker size selected.

*** The delay function is only available for 3.1 stereo and 5.1 stereo speaker configurations.

Menu entry	Selection	Value range
»MAIN MENU«		
»INPUT«	»5,1« »OPT 1« »OPT 2« »COAX 1« »COAX 2« »TV« »CD« »AUX«	
»SURROUND«	»2.1 Stereo« »3.1 Stereo« * »PLII Movie« * »PLII Music« * »5.1 Stereo« * »5.1 Direct« *	
»SPEAKER«	»3.1 Channel« »2.1 Channel«	
»LEVEL«	»Left« »Center« * »Sub«** »Right« »Side L« * »Side R« *	±12 dB ±12 dB ±12 dB ±12 dB ±12 dB
»DELAY« ***	»Center Spk« »Side Spks«	0 - -1,5 m 0 - -8,4 m
»SPEAKER SIZE«	»LLL« »LLL+Sub« »LSL« »LSL+Sub« »LSS« »LSS+Sub« »SSS+Sub«	

Setting-up the Decoderstation 5

Overall volume control

You can control the overall volume of the Decoderstation 5 at any time by turning the dial control. You can reduce the volume by turning the dial to the left and increase it by turning it to the right. The control area ranges from -54dB to +10dB. If »---« is shown on the display, you have selected the minimum volume.



Equalising the speakers*

Before familiarising yourself with the other functions of the appliance, we recommend that you perform a basic equalisation of the volume of the connected speakers. The aim of this equalisation is to set the same volume level at the listening position for each of the channels. This is the only way to achieve harmonious and balanced reproduction of the various channels.

Make sure you are in the best possible and most central place for listening. Press the standby button on the remote control and the Decoderstation 5 will be ready for use. Make sure that all signal-sources, any DVD players connected, are not active. Choose a value of -35 dB, for example, as a reference master volume.

The aim is to set the levels of the centre, sub and rear in relation to the output level set on the front speaker.

Press the »Test« button on the remote control. This activates a test tone that cycles through all satellites and the subwoofer in sequence.



First make sure that the left and right front speakers are set to 0dB. You can select the required speaker simply by pressing a button on the remote control and then adjusting its volume up to ± 12 dB using the volume buttons.

You now can increase or decrease the levels for the centre, both surround speakers and the subwoofer until you can hear these four speakers at

the same volume as both front speakers. Press the »Return« button again to complete the calibration process.

Equalisation by ear often requires several attempts and does not always provide perfect results right away. For perfect equalisation of the speakers we recommend using a volume level measuring device, available online in the Teufel shop. This device will last a lifetime and allows you to make far more precise settings than by ear. Bass levels in particular are often set too loud – exact adjustment is only guaranteed using a measuring device.

Mute

Pressing the button once will mute the Decoderstation 5. If you press it again the appliance will return to the level previously selected. The mute status is shown in the display of the Decoderstation 5.



** You only need to equalise the speakers when using a 5.1 surround set.*

In pure stereo mode, set the volumes for the left and right front speakers to 0dB each.

By lowering r raising one channel you can optimise the sound experience for an asymmetrical listening situation, similar to a balance controller.

Note

Make sure that the emitting amplifier (e.g. Concept E Magnum) reproduces all of the channels at the same volume.

Note

The volume setting of the subwoofer may be slightly different when playing back music compared with playing home cinema sound, depending on the recording quality and mixing. Whereas a solid bass element often predominates on DVDs with lots of special effects, the desired level is sometimes not achieved for music (especially if the set has been set up for ideal DVD playback). Your personal taste is the best guide for finding a compromise between the two sources. You can directly adjust the subwoofer level as required at any time using the »Subwoofer« button on the remote control.

Setting-up the Decoderstation 5

1. »INPUT« – selecting the input signal

You can choose the desired input signal source using the »INPUT« option in the menu.

The following are available:

»5.1«	Analogue 5.1 input
»OPT 1« · »OPT 2«	Optical digital inputs
»COAX 1« · »COAX 2«	Coaxial digital inputs
»TV« · »CD« · »AUX«	Analogue stereo inputs



3. »SPEAKER« – Selecting speaker configuration

You can use the »SPEAKER« option in the menu to tell the Decoderstation 5 which scope the connected speaker set has.

You can choose the following:

- »5.1 Channel«
- »3.1 Channel«
- »2.1 Channel«

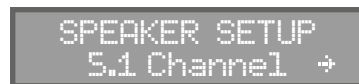

* Note

The Decoderstation 5 memorises the selected surround configuration for each input separately.

For example, you can listen to your CDs as a conventional two-channel stereo mix or your DVDs using the optical input, but always in 5.1.

2. »SURROUND« – Selecting surround configuration*

Depending on the choice of speaker configuration (see 3, »SPEAKER«) the Decoderstation 5 offers the following surround modes:

Speaker configuration

»2.1 Channel« »3.1 Channel« »5.1 Channel«

2.1 Stereo	2.1 Stereo	2.1 Stereo
3.1 Stereo	3.1 Stereo	3.1 Stereo
PLII Movie	PLII Movie	
PLII Music	PLII Music	
	5.1 Stereo	
	5.1 Direct	

The decoupling of the source signal format and the speaker configuration provides you with some practical options: You can expand the two-channel stereo signal to 3.1 (without surround speakers) and 5.0/5.1 (with surround speakers) formats. The two Dolby PLII operating modes expand the reproduction by centre and surround reproduction, according to Dolby specifications.



Use the PLII Movie setting if you are using Dolby Pro-Logic encoded media such as certain video cassettes.

Conversely you can also reproduce a multi-channel signal using a smaller surround configuration, such as 2.1. This downmix function also allows you to replace a missing subwoofer with bass management (see page 18).

If you use digital inputs, Dolby and DTS encoded formats are recognised by the Decoderstation 5 and the sound configurations are set automatically and cannot be changed.

4. »LEVEL« – Equalisation**

You can use the »LEVEL« option in the menu to adjust the levels of all of the speakers that you have registered in the »SPEAKER« menu option.

You can choose between the following entries, depending on the speaker configuration and the speaker sizes registered:

»Left«	The left front speaker
»Center«	The centre speaker
»Sub«	The subwoofer
»Right«	The right front speaker
»Side L«	The left surround speaker
»Side R«	The right surround speaker



By pressing the dial control you can access the equalisation control of the respective speaker from the level menu. You have a control range of ± 12 dB per speaker.



As a rule, you will only need this menu once for initial adjustment of your surround system. Please read page 15.

Setting-up the centre delay

5. »DELAY« – Delay *

In order for the appliance's digital signal processor (DSP) to be able to convert Dolby and DTS multi-channel signals perfectly, it must be aware of the spatial positioning of the individual boxes to each other. Distance differences between the speakers can be equalised by using a delay. The aim is that the signals from all speakers reach the listening position at the same time.

The Decoderstation 5 assumes that the front and surround speakers (side) are all positioned symmetrically to the listening position. It is also assumed that the front speakers are furthest away from the listening position.

You can use menu entries [DELAY]/[Center Spk] and [DELAY]/[Surr Spks] to enter how much closer the centre and surround speakers are positioned relative to this maximum distance. They should be at a comfortable relative distance to the front speakers.

1. Measure the distance between the listening point and the front speakers.
2. Measure the distance between the listening point and the centre speaker
3. Now subtract the distance from the centre box from the distance from the front boxes. Set this value in the Decoderstation 5; use the closest matching value. **

```
DELAY - REL DIST
Center Spk →
```

Example

Distance to the front speakers = 3,5 metres each,
Distance to the centre box = 2,6 metres.

Subtracting the distances gives the following result: $3,5 - 2,6 = 0,9$ metres.

Therefore the centre speaker is 0,9 metres closer to the listening position than the front speaker.

```
DELAY - REL DIST
Center Spk - 0,9m
```

Setting the surround delay

1. Measure the distance between the listening point and the front speakers.
2. Measure the distance between the listening point and the surround speakers.
3. Now subtract the distance from the surround speakers from the distance from the front speakers. Set this value in the Decoderstation 5; use the closest matching value. **

```
DELAY - REL DIST
+ Surr Spks
```

Example

Distance to the front speakers = 3,5 metres each,
Distance to the surround speakers = 2,0 metres each.

Subtracting the distances gives the following result: $3,5 - 2,0 = 1,5$ metres.

Therefore the surround speakers are 1,5 metres closer to the listening position than the two front speakers.

```
DELAY - REL DIST
Surr Spks - 1,5m
```

As a rule you will only need this menu once for initial adjustment of your surround system.

* Note

The delay function is only available for 3.1 stereo and 5.1 stereo speaker configurations.

** Information

The distance can be entered in 30 cm increments.

Use the setting that is as close as possible to the resulting distance.

Setting up the Decoderstation 5

6. »SPEAKER SIZE«

You can tell the Decoderstation 5 the size of your speakers using the »SPEAKER SIZE« menu option. The 5.1 speaker set-up only consists of five identical speakers, each able to reproduce the full frequency range under perfect conditions. This includes a separate subwoofer that only reproduces the LFE channel. Speakers for home cinema are generally smaller and are therefore limited in the bass range. There is no subwoofer present in other cases.

The Decoderstation 5 comes with bass management to produce a complete sound experience with these systems, too.

The function of this setting: The bass of any channel where bass is limited is routed to the full-area speakers or the subwoofer. If there is no subwoofer the bass and the LFE channel are routed to the front left and right full-area speakers.

You only need to set the speaker size in your system once. The Decoderstation 5 will then distribute frequencies among the speakers automatically and according to the Dolby and DTS standards.

The Decoderstation 5 differentiates between the front speaker pair [F] in »small« or »large«, the centre speaker [C] in »small« or »large«, the rear or side surround speaker pair [R] in »small« or »large« and a subwoofer if one is present [+ Sub].

Seven configurations are available:

The three abbreviations refer to front, centre and surround speakers (FCS).

- »LLL«
- »LLL+Sub«
- »LSL«
- »LSL+Sub«
- »LSS«
- »LSS+Sub«
- »SSS+Sub«

If you have left and right front speakers, centre or surround speakers that are large enough for deep bass reproduction, select a configuration with the entry »Large« at the corresponding position (FCS). This is the case for floorstanding speakers and large shelf speakers.* Select the setting »Small« in other cases.

Then select whether your speaker system has a separate subwoofer. This refers to active subwoofers with built-in amplifiers. Only select a configuration with »+Sub« if this is the case.*



SPEAKER SIZE
← FCS: SSS+Sub

* Notice:

When selecting "Large" in the speaker set-up the subwoofer will only reproduce 1 LFE-channel from a multi channel source such as DVD.

If there is no discrete LFE-channel (e.g. from a stereo source) the subwoofer will not carry a signal as the bass frequencies are directed to the front speakers.

»The rear satellites and/or centre will not play with stereo sources such as music CDs (e.g. via PC or DVD player).«

Use the remote control to switch the decoder into Pro Logic mode or into one of the DSP modes (3.1 stereo, 5.1 stereo).

»The decoder reacts to the remote control of another appliance / another appliance reacts to the decoder's remote control.«

As there are no clear regulations on the distribution of codes, each manufacturer can work with the code of their choice. Unfortunately, occasional crossovers in individual cases cannot be prevented. This is, however, not a fault of the Decoderstation 5!

If you have the option to choose another location and can locate the decoder outside the range of the other device's remote control (and not right next to it) this may reduce this problem, as the reception areas may then no longer overlap.

»The decoder does not respond perfectly to the remote control.«

The batteries may have been inserted incorrectly or they may be discharged: they may need to be inserted correctly or replaced. Operation could be impaired if the decoder is situated too far away or in direct sunlight.

»It is not possible to connect a 6.1 or 7.1 speaker set to the Decoderstation 5.«

The Decoderstation 5 is a 5.1 decoder and is therefore not able to decode a sixth channel (rear). 6.1 or 7.1 operation is therefore not possible.

»You cannot change the surround configuration.«

You are probably using a digital input. If a Dolby or DTS signal is being received at this input, the Decoderstation 5 will automatically switch to the correct sound configuration.

»No Dolby/DTS multi-channel tone is reproduced the digital sources connected.«

The Decoderstation 5 automatically recognises the format of the signal source when reproducing digital sources. If the decoder is not playing a multi-channel tone, there is probably no multi-channel signal present. Digital signal sources do not always have to transfer multi-channel tones but can also emit regular stereo tones (2.0). For example, this is often the case for television reception with digital receivers.

»With computer game consoles no multi-channel tones are reproduced via the digitally connected sound cards.«

Lots of sound chips are able to create surround sound in real time and emit via the analogue outputs on the sound card. However, for transfer using a digital connection, digital encoding of the multi-channel tone in a Dolby AC-3 stream is necessary. This can only be carried out if the sound card is able to perform this decoding in real time and transfer it to the decoder.

At the moment, only game consoles, such as Microsoft Xbox 360 and Sony Playstation 3 and a few sound cards with Dolby® Digital Live support are able to perform real time encoding.

»You cannot switch off the Decoderstation 5 using the remote control.«

Keep pressing the dial control until the appliance starts up again.

»The Decoderstation 5 cannot complete the start process.«

Temporarily remove the main power supply.

Teufel

Please contact our service department if you have any questions, suggestions or if there is anything you think we could do better.

Lautsprecher Teufel GmbH

Bülowstraße 66
10783 Berlin · Germany

Tel.: +49(30) 30 09 30 0

Fax: +49(30) 30 09 30 30

www.teufel.eu

All information is provided without guarantee of correctness.
Subject to technical changes, typing errors and mistakes.