

Technical description and instruction manual

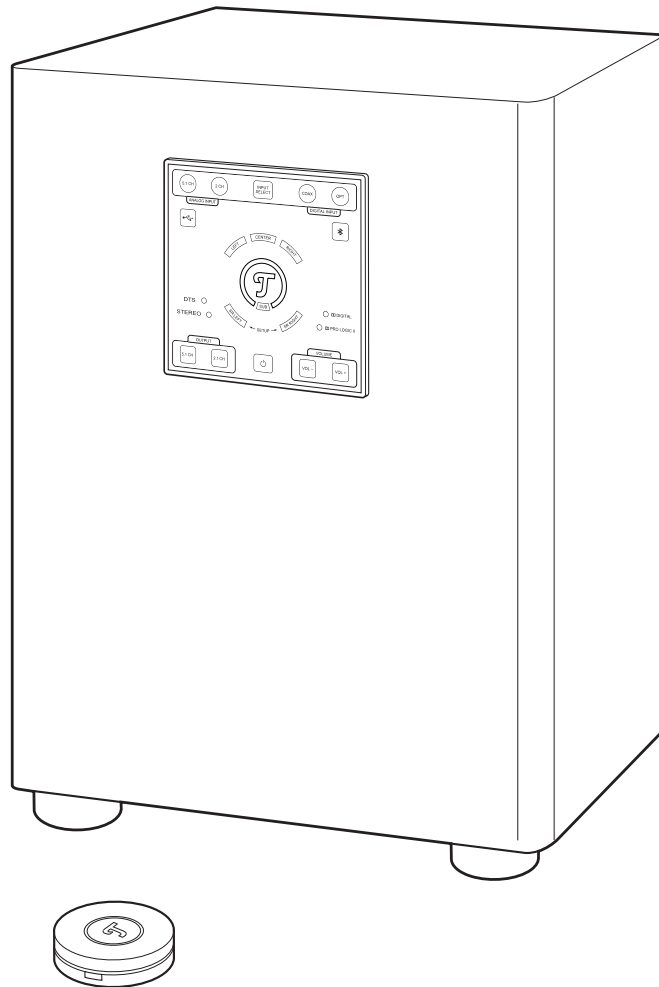

Concept E 450 Digital

Active subwoofer CM 2014 SW

Teufel

Contents

General Notes and Information	3	Remote control	12
Notice	3	Operation	13
Trademarks	3	Switching the device on/to standby.....	13
Original packaging.....	3	Selecting an input	13
Complaints.....	3	Selecting an output	14
Contact.....	3	Audio format	14
Proper use.....	3	Setting the volume	15
For your safety	4	Setup.....	15
Signal terms.....	4	Cleaning & Maintenance	16
Safety notes.....	4	Troubleshooting	17
Explanation of symbols	5	Technical data	18
Overview	6	Declaration of Conformity	18
Product Contents.....	6	Disposal	19
Operational controls and connections	6	Important information in accordance	
Control panel	6	with the Electrical and Electronic	
Setup panel	7	Equipment Act (Germany: ElektroG).....	19
Remote control	7	Important information about the	
Back side	7	Batteries Act (Germany: BattG).....	19
Preparation	8		
Unpacking.....	8		
Setup notes	8		
Connecting	9		
Connecting external players	9		
Connection examples.....	10		
Connecting satellite			
speakers	11		
Connection to the grid.....	11		

General Notes and Information

Notice

The information in this document may change without prior notice and in no way constitutes any liability on the part of Lautsprecher Teufel GmbH.

No part of this instruction manual may be reproduced in any form or be broadcasted in any way electronically, mechanically, by photocopy or recording without the written permission of Lautsprecher Teufel GmbH.

© Lautsprecher Teufel GmbH

Version 2.0, April 2022

Trademarks

® All trademarks are the property of their respective owners.



Bluetooth® and the Bluetooth® symbol are trademarks of Bluetooth SIG, Inc.



Qualcomm aptX is a product of Qualcomm Technologies International, Ltd.

Qualcomm is a trademark of Qualcomm Incorporated, which is registered in the USA and other countries; its use has been approved. aptX is a trademark of Qualcomm Technologies International, Ltd., which is registered in the USA and other countries; its use has been approved.

Original packaging

If you wish to exercise your right of return, we ask that you be absolutely sure to hold onto the packaging. We can only accept the return of a unit WITH THE ORIGINAL PACKAGING.

Empty boxes are not available!

Complaints

In case of complaint we will need the following information to process your enquiry:

1. Invoice number

Can be found on the sales slip (enclosed with the product) or on the order confirmation received as a PDF document, e.g. 4322543.

2. Serial number or batch number

Located on the back of the device,
e.g. serial #: CO 30009440122A

Thank you for your support!

Contact

Please contact our customer service with any questions, suggestions or criticism:

Lautsprecher Teufel GmbH

BIKINI Berlin

Budapester Str. 44

10787 Berlin (Germany)

Phone 00800 - 200 300 40 (toll-free)

Fax: +49 (0)30 / 300 930 930

Service: www.teufelaudio.com/service

Contact: www.teufelaudio.com/contact

Proper use

The device is designed as an amplifier and as a control unit for audio signals of external players as well as for playing back low frequencies.

Only use the device as described in this instruction manual. Any other use will be deemed as not in accordance with the instructions and may lead to damage of property or even persons.

The manufacturer cannot be held liable for damages caused by improper use.

The device is intended for private use.



Before operating the device, please read the safety notes and instruction manual carefully. Only in this way, can you ensure that all functions are used in a safe and reliable manner.

Store the instruction manual in a safe place and also be sure to pass it on to any subsequent owner.

NOTICE

Check that all items have been delivered and that nothing is damaged. If you find damage, do not operate the device; instead contact our service department.

For your safety

Signal terms

You can find the following signal terms in these instructions:

WARNING

This signal term indicates a moderate risk, which, if not avoided, may result in death or severe injury.

CAUTION

This signal term indicates a low risk, which, if not avoided, may result in minor or moderate injury.

NOTICE

This signal term warns you of potential damage.

Safety notes

Improper electrical installation or excessive mains voltage may result in an electrical shock.

- The device is suitable for a mains voltage of 230V ~ / 50Hz. When connecting the device, make sure that the correct voltage is present. You can find more information in this respect on the nameplate.
- Check the device regularly for damage. Immediately disconnect the mains plug and do not operate the device if its housing or mains cord is defective or exhibits other visible damages.
- If the mains cord of the device is damaged, only have it replaced by the manufacturer, its customer service department or a person with similar qualifications.
- This device is disconnected from the grid by pulling the mains plug. Thus, make sure that the mains plug is always easily accessible.
- If the device emits smoke, smells burnt or produces unusual sounds, immediately disconnect it from the mains and do not operate it further.
- Never open the device housing. Repairs may only be carried out by an authorised specialist workshop. In the process, only parts that correspond to the original device data may be used.
- Only use the accessory products specified by the manufacturer.

- Only use the device in indoor areas.
- Do not operate the device in wet rooms and protect it from dripping and splash water.
- Make sure that no vases or other vessels filled with liquid are located on the device or nearby in order to prevent liquid from penetrating the housing. If water or other debris ends up penetrating the housing, immediately pull the mains plug and take out any batteries. Then send the device to our service address.
- Never modify the device. Unauthorized interventions may affect the safety and functionality.
- Never touch the mains plug with wet hands.

An unsuitable setup location may result in injury and damage.

- If the speakers are not securely mounted, do not use them in vehicles, in unstable locations, on wobbly tripods or furniture, on underdimensioned brackets etc. The speakers may tip or fall over and cause injury to persons or be damaged themselves.
- Only place the subwoofer on the floor.
- Place the speakers in such a way that they cannot be knocked over inadvertently and make sure that the cables do not pose a trip hazard.
- Do not place the speakers near sources of heat (e.g. heaters, ovens, other heat generating equipment such as amplifiers etc.).
- Do not use the device in environments where there is a risk of explosion.
- Only use the Bluetooth® function in locations where wireless radio transmission is allowed.

An unstable base may cause the unit to tip and injure or even kill persons, children are particularly at risk. You can prevent a large number of accidents by taking the following precautions:

- Only place the subwoofer on the floor.
- If you want to use underframes or speaker stands, only use those recommended by the manufacturer.
- When storing the product, also ensure that it stands safely and that it cannot be knocked down or over.

Children can become trapped in the packing film when playing and suffocate.

- Do not allow children to play with the device or the packing film. Danger of suffocation.
- Ensure that children do not remove small parts from the device or take them off of the device (e.g. control knobs or plug adapters). They could swallow the parts and choke.
- Never let children use electrical equipment unsupervised.

Leaking battery acid may lead to chemical burns.

- Do not allow battery acid to come into contact with skin, eyes or mucus membranes. In the event of contact with acid, immediately flush the applicable areas with plenty of clean water and consult a physician if necessary.

Batteries (particularly lithium batteries) can explode if used improperly.



- Never attempt to recharge batteries.
- Only use batteries of the same or equivalent type.
- You may not heat or short circuit batteries and storage batteries or dispose of them in fire.
- Do not expose batteries and storage batteries to direct sunlight.

Extended listening at high volumes may lead to hearing loss.

To avoid damage to health, avoid extended listening at high volumes.

- When the volume is set high, always keep a certain distance from the device and never place your ear directly on the speaker.
- If a speaker is set to full volume, this may produce very high sound pressure. This may have psychological consequences and also cause physical injury. Children and pets are particularly at risk. Set your signal source device volume control to a low setting before turning on the power.

Explanation of symbols

	Protection class II
	Risk of electrical shock!

Overview

Product Contents

- ① 1x subwoofer CM 2014 SW
- ② 1x remote control including batteries
- ③ 1x USB cable (2 m)
- ④ 1x speaker cable, 2 x 1 mm², 30 m

The satellite speakers are delivered in separate packaging. Here you can also find the corresponding instruction manual.

- Check that all items have been delivered and that nothing is damaged. If the delivery is incomplete or exhibits transport damages, please contact our service team (see page 3).
- Never start up a damaged device.

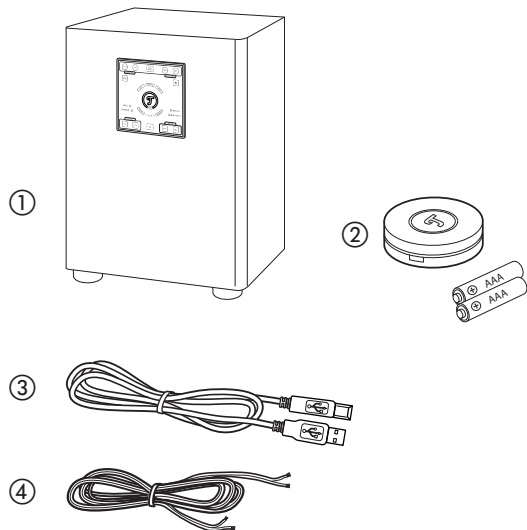

Operational controls and connections

Control panel

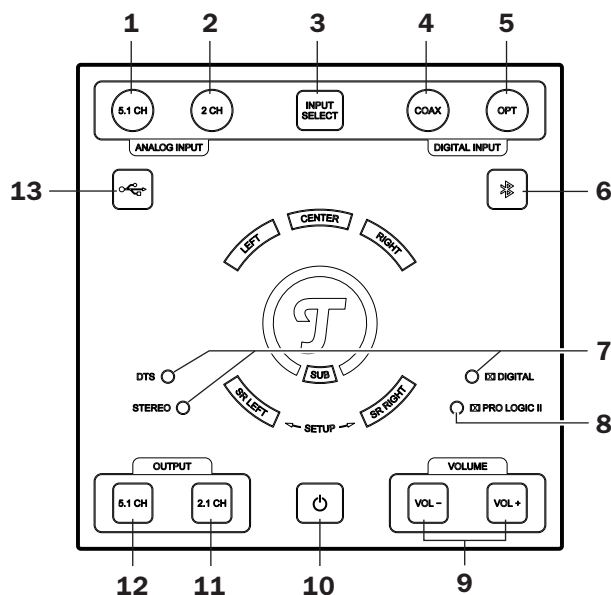

Item	Name	Description
1	5.1 CH	“Line In” input is active
2	2 CH	“Analogue In” input is active
3	Input Select	Select the input
4	COAX	“Digital In Coaxial” input is active
5	OPT	“Digital In Optical” input is active
6	Bluetooth	Select Bluetooth® as the input
7	DTS STEREO Digital	Audio format of the input signal
8	Pro Logic II	LED illuminates if 5.1 CH is set as the output (12), but if the input signal consists of fewer channels (the Concept E 450 Digital generates an upmix)
9	VOL - / +	Set the volume
10	Power	Switch the device on/to standby
11	2.1 CH	Playback: only front speakers + subwoofer
12	5.1 CH	Playback: all speakers
13	USB	Select USB as the input

Setup panel

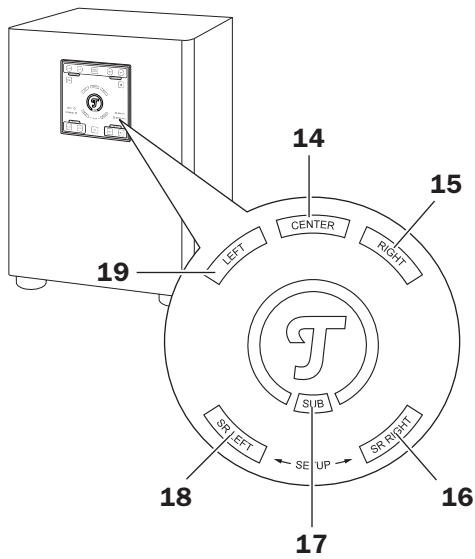

Item	Name	Description
14	CENTER	Sensor field for center speakers
15	RIGHT	Sensor field for right front speaker
16	SR RIGHT	Sensor field for right surround speaker
17	SUB	Sensor field for subwoofer
18	SR LEFT	Sensor field for left surround speaker
19	LEFT	Sensor field for left front speaker

Remote control

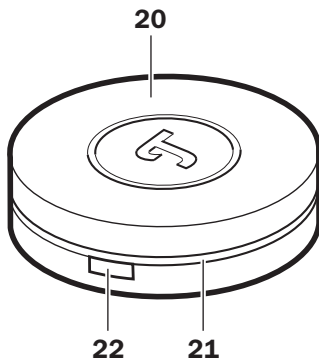

Item	Name	Description
20	Control dial	
21	LED ring	
22	Side button	

Back side

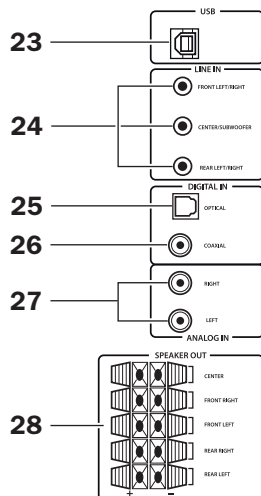

Item	Name	Description
23	USB	Input jack for the integrated USB sound card
24	LINE IN	Analogue 5.1 inputs
25	DIGITAL IN OPTICAL	Digital optical input
26	DIGITAL IN COAXIAL	Digital RCA input
27	ANALOG IN	Analogue stereo input
28	SPEAKER OUT	Outputs for satellite speakers

Preparation

Unpacking

- Carefully open the box and lift the subwoofer with the EPE foam parts out without touching the diaphragms in the subwoofer base.

Setup notes

NOTICE

If the device is subjected to warm temperatures after being cold (e.g. after transport), condensation may occur inside of it.

- *In this case, wait at least 2 hours before you connect and activate it.*

i Our website contains comprehensive notes for correct setup.

- Select a stable, level base.
- Make sure that the environment is clean and free from dust.
- Make sure that the speakers are firmly positioned to prevent vibrations.
- Select a location away from heat sources and direct sunlight.
- Lay the connector cables so that they do not pose a tripping hazard.
- Do not place any heavy objects on the cables or the speakers.
- Set up the satellite speakers such that they are at an equal distance from the listener on both the left and right side (if possible) or mount them on the wall.
- The location of the subwoofer can be freely selected and does not influence the other speakers. However, do not set it up in the corner of the room as this may result in uncontrollable frequency rises. A location between the satellite speakers is often ideal.
- On parquet, varnished wood and similar surfaces, you should stick felt gliders to the rubber feet of the subwoofer or put blankets or small carpets under them. This will prevent discolouration of the floor over the long term.

Setup as a PC sound system

- When using the device as a PC sound system, concentrating on emitting sound directly at the PC workstation is advisable, that is, the area where the monitor and listener are located.
- Please position the speakers within the grey areas.

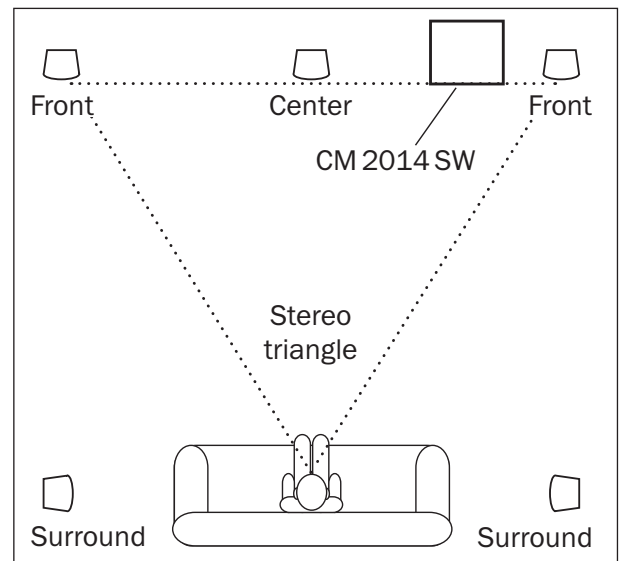

Setup in a living area

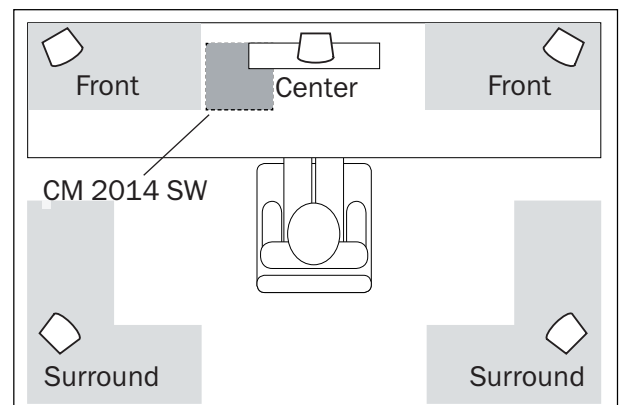

Set up as PC sound system

Connecting

Connecting external players

1. Pull the mains plug of all devices to be connected out of the socket to prevent accidental activation.
2. Connect the Concept E 450 Digital to your external players as shown in the following examples.
 - PC:
 - Connection to **USB (23)** using a USB cable. Set audio output on the PC to the USB sound device or similar. You can download a suitable driver for Windows® from the product web site at www.teufelaudio.com.
 - Decoder station, ControlStation or PC with 5.1 sound card:
 - Connection to **LINE IN (24)** using 3 stereo cables “RCA to a 3.5 mm TRS” or “TRS to TRS (3.5 mm)”.
 - Blu-ray player or Smart-TV:
 - Connection to **DIGITAL IN OPTICAL (25)** using an optical cable with TOSLINK plugs or using a coax cable.
 - Satellite receiver:
 - Connection to **DIGITAL IN COAXIAL (26)** using an RCA cable or an optical cable.
 - MP3 player:
 - Connection to **ANALOGUE IN (27)** using a stereo cable “RCA to 3.5 mm TRS”.

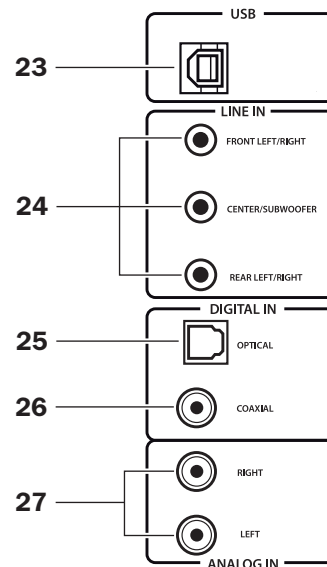

You can find suitable cables in our web shop.

You can also connect a smartphone or tablet to the Concept E 450 Digital via Bluetooth® (see “Bluetooth® pairing” on page 14).

Connection examples

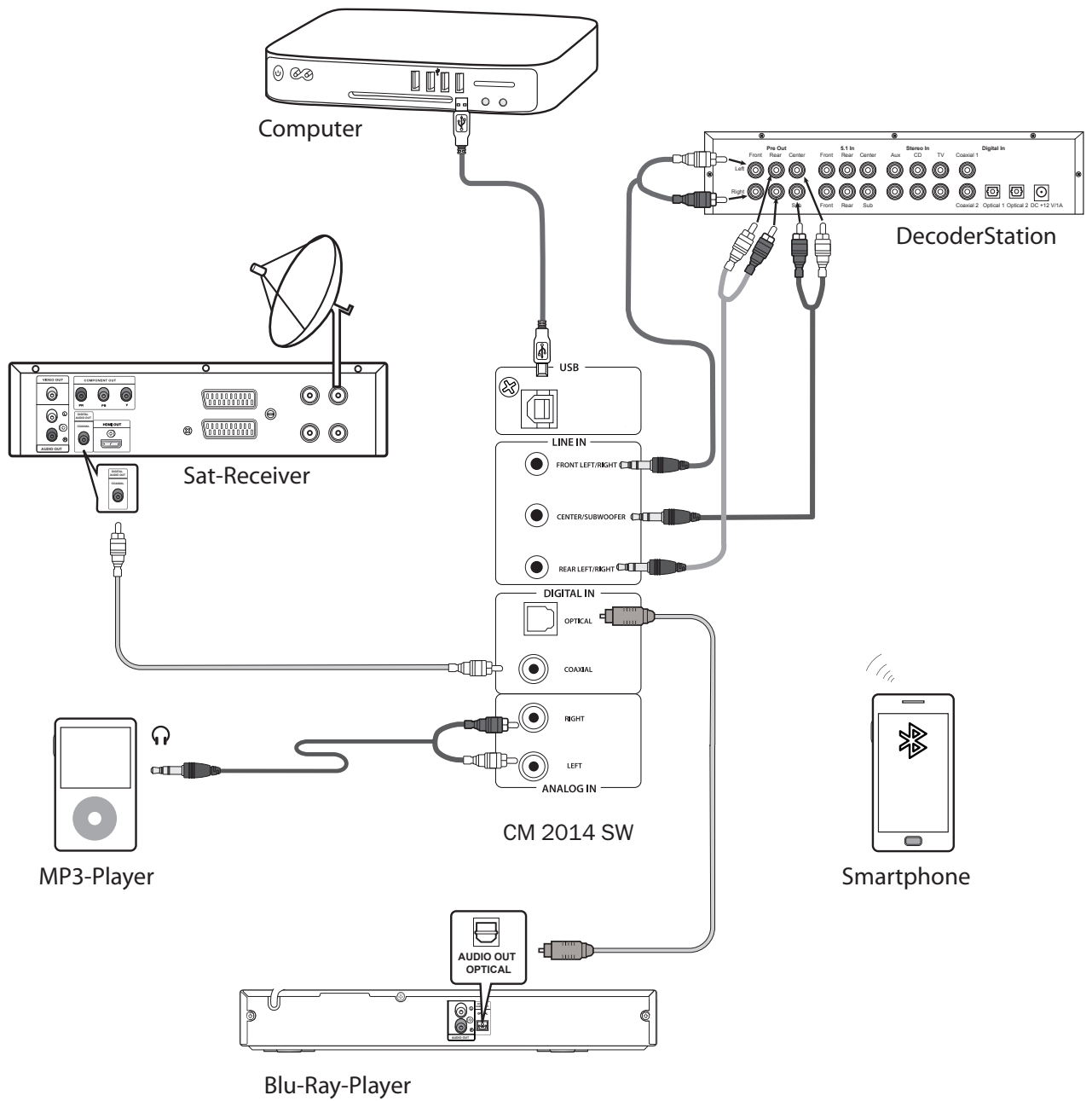

Connecting satellite speakers

⚠ CAUTION

The speaker cables may pose a tripping hazard.

- Lay the cables so that no one can get caught in them.

NOTICE

Make sure the polarity is correct!

- Connect the like coloured terminals. Otherwise, the sound quality will suffer. The strands of the speaker cables are marked with different colours or shapes.

1. The connector terminals **SPEAKER OUT (28)** for the satellite speakers are located on the back side of the Concept E 450 Digital. Run the speaker cables from the subwoofer to each satellite speaker. Small piece of advice: Label the cables on the subwoofer end – this facilitates setup and tear-down of the system.
2. Split the speaker cables down to approx. 30 mm on both ends and strip approx. 10 mm of insulation off of each cord.
3. Twist the stripped single wire ends together so that no wire protrudes. Tin coating is not necessary.
4. Push down the connector terminal levers and run the stripped cable ends into the corresponding holes. When releasing the lever, the cable ends will be locked. Connect all cables to the subwoofer in this way. Ensure that no part of the insulation is clamped in place.
5. Connect the other ends of the speaker cables to the satellite speakers. The instruction manual of the speakers should contain notes on this.

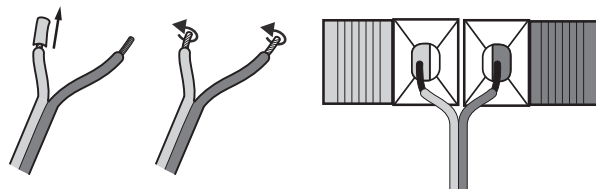
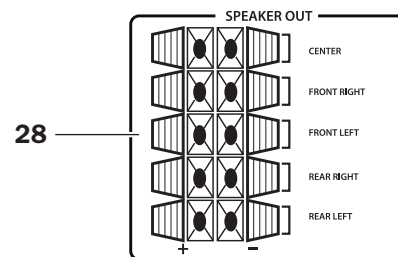

Connection to the grid

- Insert the mains plug in an easily accessible mains socket.
- Plug the mains plugs of your external players back into the mains socket.

Remote control

The remote control is magnetic and can be fixed in place on the setup panel.

Changing the batteries

The remote control is powered by 2 type AAA batteries. Simply pull off the control dial (20) to open the battery compartment.

CAUTION

Leaking battery acid may lead to chemical burns.

- Do not allow battery acid to come into contact with skin, eyes or mucus membranes. In the event of contact with acid, immediately flush the applicable areas with plenty of clean water and consult a physician if necessary.

Batteries (particularly lithium batteries) can explode if used improperly.

- Never attempt to recharge batteries.
- Only use batteries of the same or equivalent type.
- You may not heat or short circuit batteries and storage batteries or dispose of them in fire.
- Do not expose batteries and storage batteries to direct sunlight. Changing the battery

Pairing of the remote control

The remote control is already paired with the system by default. If the connection is interrupted at some point, the pairing process must be repeated. In such a case, proceed as follows:

1. Turn the Concept E 450 Digital on.
2. Position the remote control at a distance of no more than 25 cm to the Concept E 450 Digital.
3. Hold the side button (22) down until the LED ring (21) starts to blink and release it.
 - Blinks three times: Pairing was successful.
 - Blinks ten times: Pairing failed and must be repeated.

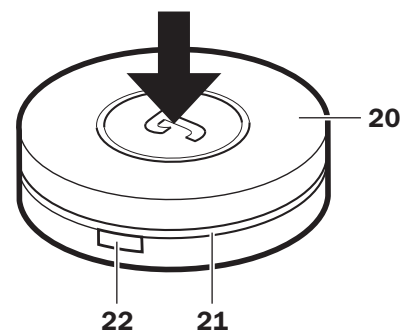
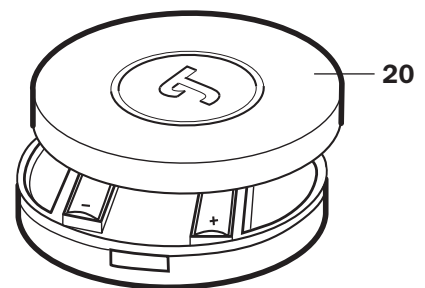
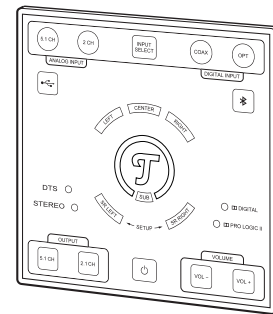

Functions

- Activating the Concept E 450 Digital: Push the middle of the control dial **(20)**.
- Switching the Concept E 450 Digital to standby: Push and hold the control dial **(20)** for 3 seconds.
- Adjusting the volume: Turn the control dial **(20)**.
- Activating/deactivating mute: Briefly press the control dial **(20)**.
- Selecting the input: Push the side button **(22)** (repeatedly). Pushing the button selects the next input (see table on the right).

Selected input	LED illuminates:
LINE IN (24)	5.1 CH (1)
ANALOGUE IN (27)	2.1 CH (2)
DIGITAL IN COAXIAL (26)	COAX (4)
DIGITAL IN OPTICAL (25)	OPT (5)
BLUETOOTH	⌘ (6)
USB (23)	🔌 (13)

Operation

Switching the device on/to standby

Activating

- **On the device:** Briefly push the button **(10)**.
- **With the remote control:** Briefly press the middle of the control dial **(20)**.

The following LEDs illuminate when the device is activated:

- the selected input **(1, 2, 4, 5, 6 or 13)**
- the volume display
- the active speakers (5.1 or 2.1)
- the audio format of the input signal

The last settings that were used will still be active even after the device has been turned on.

Switching to standby

- **On the device:** Briefly push the button **(10)**.
- **With the remote control:** Push and hold the middle of the control dial **(20)** for approx. 3 seconds.

The button **(10)** will illuminate in standby.

Selecting an input

- **On the device:** Push the button **INPUT SELECT (3)** repeatedly until the LED of the desired input illuminates.
- **With the remote control:** Push the side button **(22)** repeatedly until the LED of the desired input illuminates **(1, 2, 4, 5, 6 and 13)**.
- You can select the Bluetooth® and USB inputs by tapping the button **⌘ (6)** or **🔌 (13)**.

Volume display

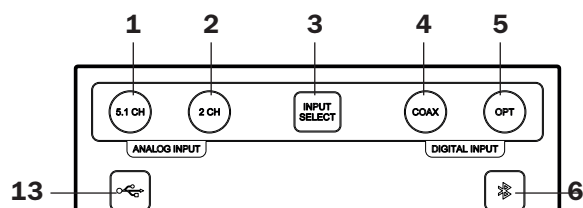
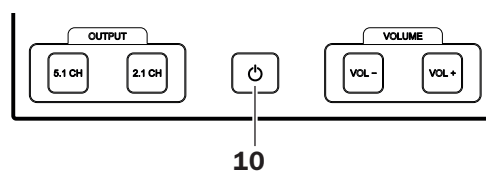
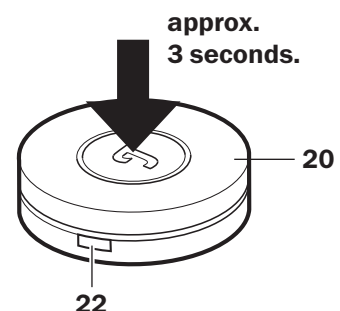
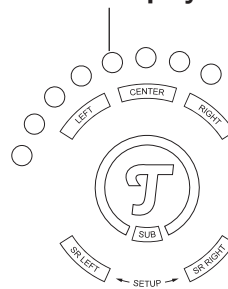

Bluetooth® pairing

You can connect compatible devices, such as most smartphones, with your Concept E 450 Digital via Bluetooth® (pairing). The sound output of the smartphone then occurs via the Concept E 450 Digital.

1. Use the **button (6)** to select the “Bluetooth®” input. The button will now illuminate.
2. Activate the Bluetooth® function on your external player (e.g. smartphone).
3. Let your smartphone scan for Bluetooth® devices. You can find more information about this in the instruction manual for your smartphone. “Teufel Concept E” should appear in the list of the detected devices after the search run.
4. Select the Teufel Concept E from the list of detected devices. Pairing is now complete and your Concept E 450 Digital will now function similar to Bluetooth® headphones. The Concept E 450 Digital will now play back all sounds that would otherwise be played by your smartphone.
5. Deactivate the Bluetooth® function on your external player to terminate the Bluetooth® connection.

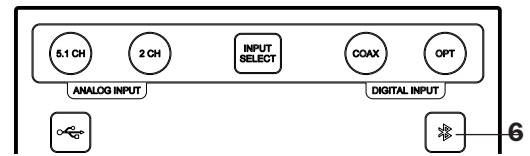

Selecting an output

You can select whether sound output will be played via all speakers or just the front speakers and subwoofer.

- Button 2.1 CH (**11**): Playback via the front speakers + subwoofer.
- Button 5.1 CH (**12**): Playback via all speakers.

The corresponding sensor fields of the speakers (**14** - **19**) will illuminate depending on the setting.

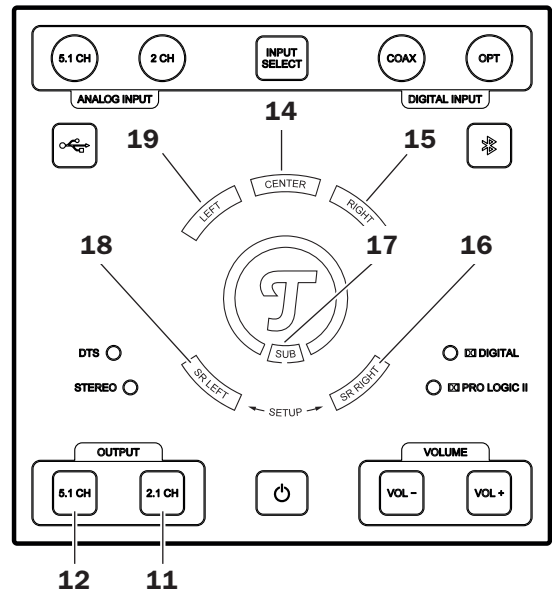

Audio format

The LEDs (**7**) and (**8**) indicate the audio format:

Input signal	Output	LED illuminates
Stereo	2.1 CH (11)	Stereo (7)
	5.1 CH (12)	<input checked="" type="checkbox"/> PRO LOGIC II (8)
Dolby Digital	5.1 CH (12)	<input checked="" type="checkbox"/> Digital (7)
DTS Digital Surround	5.1 CH (12)	DTS (7)

i If you have set the output to 5.1 CH (12), but the input signal consists of fewer channels, the Concept E 450 Digital will generate an upmix and emit sound in PRO LOGIC II.

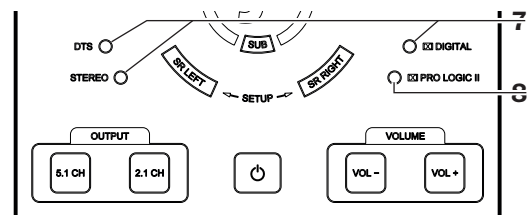

Setting the volume

Setting the system volume

- **On the device:** Adjust the volume of the entire system using the buttons **Vol +/- (9)**.
- **With the remote control:** Adjust the volume by turning the control dial (20).

The set volume will also appear optically on the volume display.

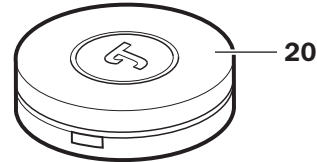
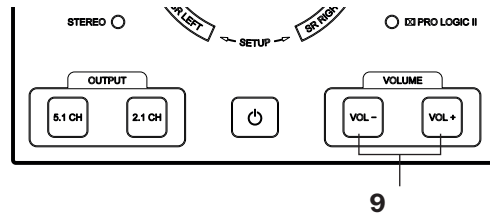

Setting the volume of the individual speakers

1. Tap on the sensor field (**14 – 19**) of the corresponding speaker. The sensor field will illuminate and the current set volume be displayed.
2. Set the volume for the selected speaker with the buttons **Vol +/- (9)** or the control dial (**20**) of the remote control.
3. Follow the same steps, if applicable, with the other speakers.

Mute

- By briefly pressing on the middle of the control dial (**20**) repeatedly, you can turn the sound on or off.

Setup

In setup mode, you can check the volume of the individual speakers and make permanent settings.

4. At the same time, tap on the sensor fields **SR RIGHT (16)** and **SR LEFT (18)** to enable setup mode. The sensor field **LEFT (19)** will illuminate; you will hear noise from the left front speaker; the volume set for the speaker will be displayed.
5. If applicable, correct the volume using the buttons **Vol +/- (9)** or the control dial (**20**) on the remote control. After 5 seconds without any input, the next speakers will be actuated one after another (CENTER ⇒ RIGHT ⇒ SR RIGHT ⇒ SR LEFT ⇒ SUB ⇒ normal mode). By pushing on the middle of the control dial (**20**), you can select the previous speaker again (ends at LEFT).
6. Set the optimal volume for each speaker this way. After the subwoofer has been set, the Concept E 450 Digital returns to normal mode. The settings are saved as a result.

Volume display

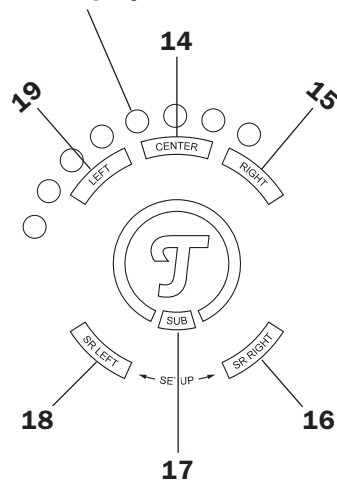

Cleaning & Maintenance

Clean the speakers regularly with a soft, damp microfibre cloth. Please be absolutely sure to observe the following notes in the process:

CAUTION

In contact with live parts, water can lead to electric shock or short circuit.

- *Make sure that no liquids penetrate the unit.*
- *Disconnect the mains plug before cleaning.*

NOTICE

External influences may damage or destroy the device.

- *If the device is to be left unattended for a prolonged period of time (e.g. during a vacation) or if a thunderstorm is forecast, pull the mains plug out of the socket. Otherwise, sudden overvoltage could cause the device to become defective.*

- *In the event of prolonged absence, remove the batteries from the remote control. Leaked batteries may damage the remote control.*
- *If possible, only use plain water without any additives. In case of stubborn marks, a mild soap solution may be used.*
- *Do not use caustic cleaning products, white spirit, thinners, petrol or similar under any circumstances. Such cleaning agents may damage the delicate surface of the housing.*

Troubleshooting

The following notes and further detailed information on our website should help you to rectify malfunctions. In case you don't succeed, please contact our hotline ☎ Phone 00800 - 200 300 40 (toll-free). Please also observe the warranty notes.

Problem	Possible cause	Solution
The device doesn't emit any sound.	The volume is set to "0".	Increase the volume.(see "Setting the volume" on page 15)
	Input signal is too weak.	Increase the volume on the external player.
	Incorrect input selected.	Select the correct input (see "Selecting an input" on page 13).
The remote control does not work.	No connection between the remote control and Concept E 450 Digital.	Establish a connection (see "Pairing of the remote control" on page 12).
	Batteries are empty.	Insert new batteries (see "Changing the batteries" on page 12).
Not all speakers are active.	The output has been set to 2.1 CH.	Switch the output to 5.1 CH (see "Selecting an output" on page 14).
Some speakers are too quiet and some are too loud.	The balance between the individual speakers is incorrect.	Adjust the volume (see "Setting the volume of the individual speakers" on page 15) and (see "Setup" on page 15).
The subwoofer hums.	The humming is caused by problems with the power supply.	Buy a line filter and connect it to the unit.
	The humming is caused by a multiple socket strip.	Use a different multiple socket strip or connect the subwoofer directly to the wall socket. It may also help to insert the mains plug in the socket the other way around.
The audio source is not played back.	An inappropriate digital output format has been set on the player.	Set the digital output format to "PCM" in the setup menu of your player.
Playback is noisy.	Generally speaking, the Concept E 450 Digital is a very low-noise system. In most cases, speaker systems with excellent resolution in the high range area expose the poor quality of a signal source (e.g. from MP3 files).	Make sure that the external player emits a clear signal to the Concept E 450 Digital.

Technical data

Max. power consumption:	500 W
Operating voltage:	230 V~, 50 Hz
Dimensions (W x H x D)	40 x 40 x 62 cm
Net weight:	25.3 kg

You can find further technical data on our website.

No responsibility is assumed for the correctness of this information. Technical changes, typographical errors and other errors reserved.

Declaration of Conformity



Lautsprecher Teufel GmbH declares that this product complies with Directive 2014/53/EU. The full text of the EU Declaration of Conformity can be found at this web address:

www.teufel.de/konformitaetserklaerungen
www.teufelaudio.com/declaration-of-conformity

The following radio frequency bands and radio transmitters are used in this product:

Radio network	Frequency bands in Mhz	Transmitter power in mW/dBm
Bluetooth®	2400–2483.5	2.5/4
Nordic	2400–2483.5	2.5/4

Disposal

Important information in accordance with the Electrical and Electronic Equipment Act (Germany: ElektroG)

We advise owners of electrical and electronic appliances that old electrical and electronic devices must be handed in separately from municipal waste, in accordance with the applicable regulations. Batteries and rechargeable batteries that are not firmly enclosed in old electrical devices and lamps, and that can be removed from the old device without destroying them, must be separated from them in a non-destructive manner before they are handed to the collection point for their intended disposal. Please take note of our information on the Batteries Act [Germany: BattG] below for disposing of batteries.

You make an important contribution to returning, recycling and further processing of old devices if you separate your old devices into the correct collection groups for recycling.

The symbol below of a crossed-out dustbin, applied to electrical and electronic appliances, also advises of the duty to separate collections:



Consumer electronics stores and supermarkets are obliged, under certain conditions, to take back old electrical and electronic devices, in accordance with section 17 of the Electrical and Electronic Equipment Act. Stationary retailers must take back an old electrical device of the same type when a new electrical device is bought (1:1 return). This also applies to home deliveries. These retailers must also take back up to three small old electrical devices ($\leq 25\text{cm}$) without this being linked to a new purchase (0:1 return).

In accordance with the Electrical and Electronic Equipment Act, as online retailers of electrical devices and due to our product range, our obligation is limited to 1:1 return of large devices of $> 50\text{ cm}$ when selling a new electrical or electronic device of the same type. We comply with the obligation of return of devices other than large devices through our service provider. You can find the exact contact data and collection points on our website www.Teufel.de/entsorgung. It is also possible to return old electrical and electronic appliances free of charge at an official delivery point run by the public waste disposal authorities.

Important: For safety reasons we ask that you refrain from sending lighting fixtures (some lamps). For return of lighting fixtures please use the public waste disposal collection points or contact us directly at www.Teufel.de/entsorgung.

As an end-user, you are responsible for deleting any personal data on old electrical appliances before handing it in.

Important: Our appliances can contain batteries/rechargeable batteries. If this is the case, please refer to its attached product documentation for additional information on the type and chemical make-up of the battery. For products with battery compartments you can directly remove the batteries or rechargeable batteries and dispose of them properly. If the batteries are built in to the product, do not in any case attempt to remove the batteries yourself, instead contact one of our employees or appropriate specialist staff.

Important information about the Batteries Act (Germany: BattG)

Batteries and rechargeable batteries must not be disposed of in household waste.

Old batteries can contain toxic substances that could damage the environment or your health if not stored or disposed of properly. This applies especially to improper handling of batteries containing lithium.

However, batteries also contain important raw materials such as iron, zinc, manganese and nickel and these can be reused. Separate collection enables recycling of these raw materials and avoids any negative impact on the environment or human health due to toxic substances being released.



The crossed-out dustbin symbol means that you should not dispose of old batteries and rechargeable batteries in household waste. In addition, you, as the end-user, are legally obliged to return old batteries.

You can hand in batteries and rechargeable batteries free of charge at an official return point such as any public waste disposal collection point. You can also hand in old batteries, that we stock or have stocked as new batteries, at one of our Teufel stores or at one of our dispatch warehouses. However,

if you send them to our dispatch warehouses we would like to point out the dangerous goods regulations of the dispatch provider you opt for and ask you not send batteries to us by post. You can get the addresses of our dispatch warehouses from our customer service.

Due to existing legal regulations, the battery manufacturer must use the following symbols with the following meanings when marking the batteries.

Hg: the battery contains more than 0.0005 mass percent of mercury

Pb: the battery contains more than 0.004 mass percent of lead

Cd: the battery contains more than 0.002 mass percent of cadmium

Otherwise, to avoid waste and littering, batteries with a long service life or rechargeable batteries should be used. Exchangeable rechargeable batteries enable long service for electrical and electronic appliances and thus devices and rechargeable batteries can be prepared for recycling (e.g. regenerating/exchanging rechargeable batteries).

Further information on preventing waste for consumers can, however, be found in the Federal waste prevention programme with the participation of the Federal states.

Teufel

Please contact our customer service department with any questions, suggestions, or complaints:

Lautsprecher Teufel GmbH
BIKINI Berlin
Budapester Str. 44
10787 Berlin (Germany)
www.teufelaudio.com

Phone.: 00800 200 300 40 (toll-free)
Fax: +49 (0)30 - 300 930 930
Service: www.teufelaudio.com/service
Contact: www.teufelaudio.com/contact

No responsibility is assumed for the correctness of this information. Technical changes, typographical errors and other errors reserved.