

Technical Description And User Manual

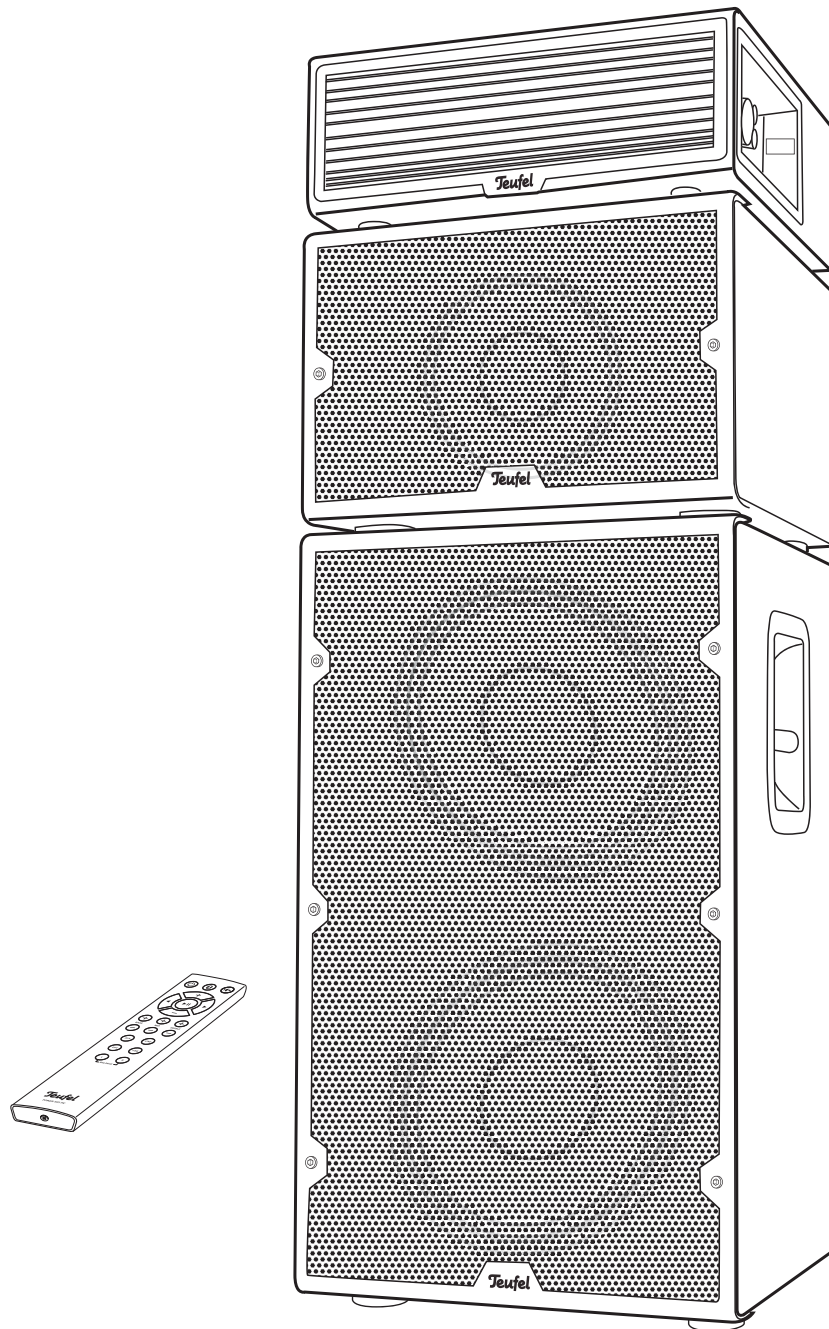

POWER HIFI

Fully active, modular speaker system

Teufel

Contents

General Notes And Information	3	Bluetooth® Mode	22
Notice.....	3	Bluetooth® options.....	22
Trademarks.....	3	Bluetooth® pairing.....	22
Original packaging	3	Restoring the connection	
Complaints	3	with a paired external player.....	22
Contact	3	Interruption of connection.....	23
For Your Safety.....	4	Playback.....	23
Proper use	4	Party mode	23
Label description	4	Terminating the connection.....	23
Safety notes	4	USB Sound Card	24
Explanation of symbols.....	6	Mac OS X	24
Overview	7	“Sound” system preference	24
Unpacking.....	7	Windows 7, 8 and 10:	24
Package contents	7	“Sound” control panel	24
Checking the package contents.....	7	Playback.....	25
Introduction	8	Software Update.....	26
Controls And Connections.....	9	Installing new software.....	26
Remote Control	10	Care And Cleaning.....	27
Inserting/changing the batteries	10	Troubleshooting.....	28
Setup.....	11	Technical Data	30
Setup location	11		
Connecting.....	12		
Connecting the speakers.....	12		
Inputs for source devices	12		
Analogue sources LINE IN, AUX IN	12		
Digital source.....	12		
USB Sound Card.....	12		
Output for companion mode	13		
Mains connection.....	13		
Operation.....	14		
Activating and deactivating.....	14		
Automatic activation/deactivation.....	14		
Selecting a source	15		
Adjusting the volume	15		
Mute.....	15		
Balance	16		
Adjusting the sound	16		
Setting the stereo channel.....	16		
Locking the control panel.....	16		
Mode	17		
MASTER	17		
COMPANION	17		

General Notes And Information

Notice

The information in this document may change without prior notice and in no way constitutes any liability on the part of Lautsprecher Teufel GmbH.

No part of this user manual may be reproduced in any form or be broadcasted in any way electronically, mechanically, by photocopy or recording without the written permission of Lautsprecher Teufel GmbH.

© Lautsprecher Teufel GmbH

Version 1.0

July 2019

Trademarks

© All trademarks are the property of their respective owners.

 The Bluetooth® word mark and Bluetooth® symbol are registered trademarks of Bluetooth SIG, Inc. and any use by Lautsprecher Teufel is licensed.

 Qualcomm® aptX™ 

Qualcomm aptX is a product of Qualcomm Technologies International, Ltd.

Qualcomm is a trademark of Qualcomm Incorporated, registered in the USA and other countries, whose use has been approved. aptX is a trademark of Qualcomm Technologies International, Ltd., registered in the USA and other countries, whose use has been approved.

Original packaging

If you wish to exercise your eight-week right of return, we ask that you be absolutely sure to hold onto the packaging. We can only accept the return of the speakers WITH THE ORIGINAL PACKAGING.

Empty boxes are not available!

Complaints

In case of a complaint we will need the following information to process your enquiry:

1. Invoice number

Can be found on the sales slip (enclosed with the product) or on the order confirmation received as a PDF document, e.g. 4322543.

2. Serial number or batch number

Located on the back side of the device, e.g. serial no.: KB20240129A-123.

Thank you for your support!

Contact

Please contact our customer service department with any questions, suggestions, or complaints:

Lautsprecher Teufel GmbH
BIKINI Berlin
Budapester Str. 44
10787 Berlin (Germany)

Telephone: 00800 200 300 40 (tollfree)

Fax: +49 (0)30 / 300 930 930

Online support:

www.teufelaudio.com/service

Contact form:

www.teufelaudio.com/contact

For Your Safety

Proper use

The POWER HIFI is designed for the playback of audio signals via Bluetooth or via direct connection to external players.

Only use the active speaker as described in this user manual. Any other use will be deemed as not in accordance with the instructions and may lead to damage to property or even persons.

The manufacturer accepts no liability for damage caused by improper use.

The active speaker is intended for private use.



Before operating the amplifier for the first time, please first read the safety notes and user manual carefully. This is the only way to use all functions safely and reliably. Store the user manual in a safe place and also be sure to pass it on to any subsequent owner.

Label description

You can find the following signal terms in this user manual:

WARNING

Indicates a moderate risk, which, if not avoided, may result in severe injury.

CAUTION

Indicates a low risk, which, if not avoided, may result in minor or moderate injury.

NOTICE

Warns you of potential damage to equipment.

Safety notes

This chapter contains general safety notes which you should always observe to protect yourself and third parties. Also observe the warning notes in each chapter of this user manual.

WARNING

Improper electrical installation or excessive mains voltage may result in an electrical shock.

- The device is suitable for a mains voltage of 220–240 V, 50 Hz. When connecting the device, make sure that the correct voltage is present. You can find more information about this on the rating plate.
- Check the device regularly for damage. Immediately disconnect the mains plug and do not operate the device if its housing or mains cord is defective or exhibits other visible damages.
- This device is disconnected from the grid by pulling the mains plug. Thus, make sure that the mains plug is always easily accessible.
- If the device emits smoke, smells burnt or produces unusual sounds, immediately disconnect it from the mains and do not operate it further.
- Never touch the mains plug with wet hands.
- If the mains cord is damaged, replace it with an equivalent one.
- Never open the device housing. Repairs may only be carried out by an authorised specialist workshop. Only parts that match the original specifications may be used.
- Never modify the device. Unauthorised modifications may affect the safety and functionality.
- Only use the accessory products specified by the manufacturer.
- Only use the device indoors.
- Do not operate the device in wet rooms and protect it from dripping and splashing water. Make sure that no vases or other liquid-filled objects are located on or near the device in order to prevent liquid from penetrating the housing. If water or any foreign objects have entered the housing, immediately disconnect the mains plug and send the device to our service address.

⚠ WARNING

An unsuitable setup location may result in injury and damage.

- If the active speaker is not securely mounted, do not use it in vehicles, in unstable locations, on wobbly tripods or furniture, on underdimensioned brackets etc. The components could tip or fall over and cause injury to persons or be damaged themselves.
- Set the components up so that they cannot be knocked over inadvertently and make sure that the cables do not pose a trip hazard.
- Carefully follow the user manual.
- Do not place the amplifier near heat sources (e.g. heaters, ovens, other heat generating equipment such as amplifiers etc.).
- Avoid prolonged exposure to direct sunlight. This may cause the housing to be discoloured.

⚠ WARNING

An unstable base may cause the unit to tip and injure or even kill persons, children are particularly at risk. You can prevent a large number of accidents by taking the following precautions:

- If possible, place the speakers on the ground.
- When storing the product, also ensure that it stands safely and that it cannot be knocked down or over.

⚠ WARNING

Children can become trapped in the plastic wrapping when playing and suffocate.

- Do not allow children to play with the device or the plastic wrapping. There is a danger of suffocation.
- Ensure that children do not remove small parts from the device or take them off of the device (e.g. control knobs or plug adapters). They could swallow the parts and choke.

⚠ CAUTION

The total system weighs 60 kg.

- Make sure that the floor has the required load-bearing capacity.
- Only carry/transport the individual components
 - **never** the entire system stacked on top of one another.
- The additional weight limit of the toppart/amplifier is 5 kg. Do not go above this limit.

⚠ CAUTION

Leaking battery acid may lead to chemical burns.

- Do not allow battery acid to come into contact with skin, eyes or mucous membranes. In the event of contact with acid, immediately flush the applicable areas with plenty of clean water and consult a physician if necessary.

⚠ CAUTION

Batteries can explode if handled improperly.

- Never attempt to recharge batteries.
- Only use batteries of the same or equivalent type.
- You must not heat or short circuit batteries and rechargeable batteries or dispose of them in fire.
- Do not expose batteries and rechargeable batteries to direct sunlight.

⚠ CAUTION



Extended listening at high volumes may lead to hearing loss.

To avoid damage to health, avoid extended listening at high volumes.





- When the volume is set high, always keep a certain distance from the device and never place your ear directly on the speakers.
- If an amplifier is set to full volume, this may produce very high sound pressure. This may have psychological consequences and also cause physical injury. Children and pets are particularly at risk. Set the volume control to a low setting when switching on the device.

⚠ CAUTION

This product contains magnetic material.

- If necessary, consult your physician and ask for effects on implants such as pacemakers or defibrillators.
- Keep magnetically sensitive objects (e.g. credit cards etc.) away from the speakers.

Explanation of symbols

	<p>Protection class II Dual insulation</p>
	<p>Risk of electrical shock Do not open the housing.</p>
 	<p>Old devices must not be disposed of with household waste!</p> <p>If the unit is no longer operational, every consumer is required by law to dispose of used devices separately from household waste, e.g. at a collection point run by the communal authority/borough. This ensures that old devices are recycled in a professional manner and also rules out negative consequences for the environment.</p> <p>For this reason, electrical equipment is marked with the adjacent symbol.</p>
	<p>Batteries and rechargeable batteries do not belong in the household garbage!</p> <p>Every consumer is required by law to bring all batteries and rechargeable batteries, regardless whether they contain harmful substances* or not, to a collection point run by the communal authority/borough or to a retailer, so that they can be disposed of in an environmentally friendly manner.</p> <p>Please only turn in batteries and rechargeable batteries which are empty!</p> <p>* labelled with: Cd = cadmium, Hg = mercury, Pb = lead</p>

Unpacking

- Carefully open the box, take out the EPE foam half-shells and carefully lift the speakers out of the box.

Package contents

- (1) 1× control unit with high-range speaker
- (2) 1× mid-range speaker
- (3) 1× low-range speaker
- (4) 1× remote control POWER HIFI RC
- (5) 1× mains cord for (1)
- (6) 2× LR03/Micro/AAA batteries for (4)

Optional accessories

- (7) 1× XLR connector cord for master/companion mode (available in our online shop)

Checking the package contents

- Check that all items have been delivered and that nothing is damaged.
- If the delivery is incomplete or exhibits damage from transport, please contact our service team (see page 3).

NOTICE

Do not operate the device if you identify damages on it.

NOTICE

If the device is subjected to warm temperatures after being cold (e.g. after transport), condensation may occur inside of it.

- *In this case, wait at least 2 hours before you connect and activate it.*

(1)

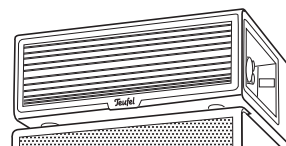

(2)

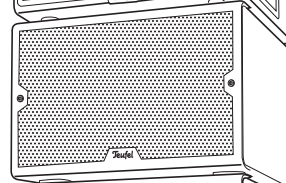

(3)

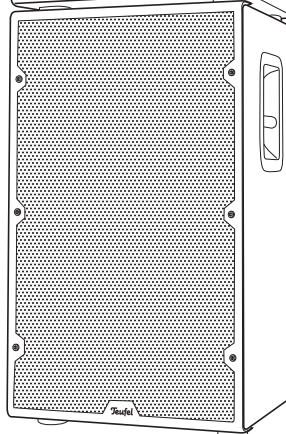

(4)

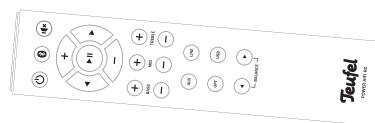

(5)

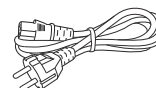

(6)



(7)

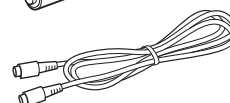

Introduction

The POWER HIFI speaker sound system is for music enthusiasts with high standards, who prefer high-quality audio playback of various styles of music like jazz, big band and brass band, rock, gospel, soul, techno, house, but also film music. The extended dynamic range of the POWER HIFI speaker system is both impressive and delightful in every listening session since the musical content that is played back sounds like you're at a live concert.

POWER HIFI brings the crisp, high sound pressure, which the ROCKSTER is known for, as well as the extended dynamic range of audio playback to your living room and similar environments.

The amplifier has its own 3-band sound control (bass, approx. 100 Hz/middle bands approx 1 kHz/treble bands, approx. 10 kHz), that can be used to adjust the sound to perfectly suit the local acoustics.

The following inputs are available for your source devices:

- Bluetooth®
- USB sound card for PC and Mac
- AUX IN (stereo via RCA)
- LINE IN (stereo via XLR)
- OPT IN (stereo via Toslink e. g. the Teufel Streamer)

The respective stereo channel that is not played back is transmitted via the output LINE OUT (via XLR). Here, you can control an additional POWER HIFI as a companion.

In master/companion mode, a POWER HIFI provides all controls as the master and it controls the second POWER HIFI, the companion for which all controls are locked except for the volume adjustment and standby function.

To the side, you can find some examples for the configuration. Detailed connection examples can be found in the section „Mode“ on page 17.

Stereo setup

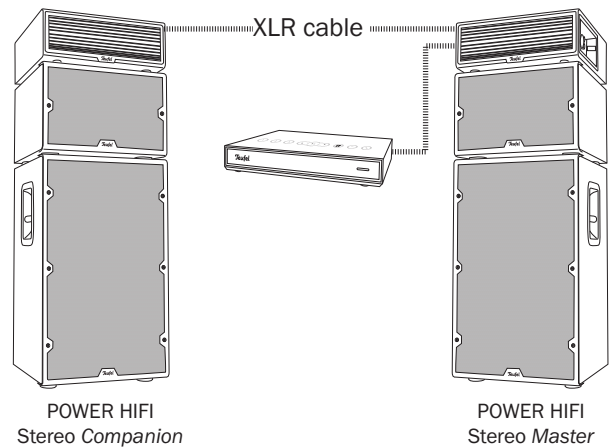

Stereo setup with mixing console and two companions

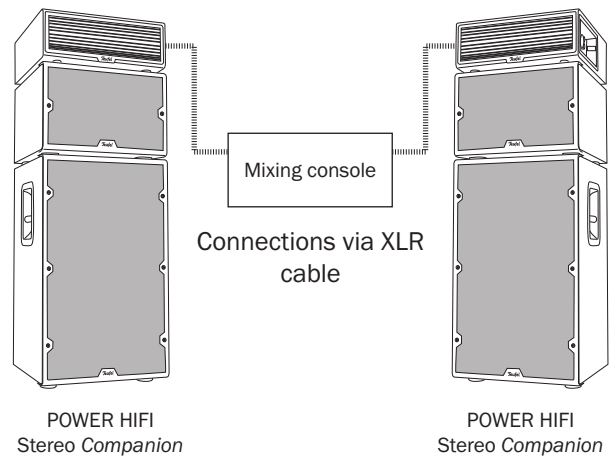

Mono setup with a master and multiple companions

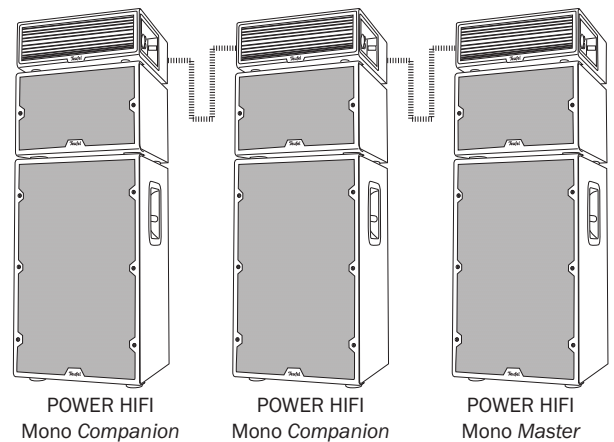

Each input on the master can be used, cascade connection via XLR cable

Controls And Connections

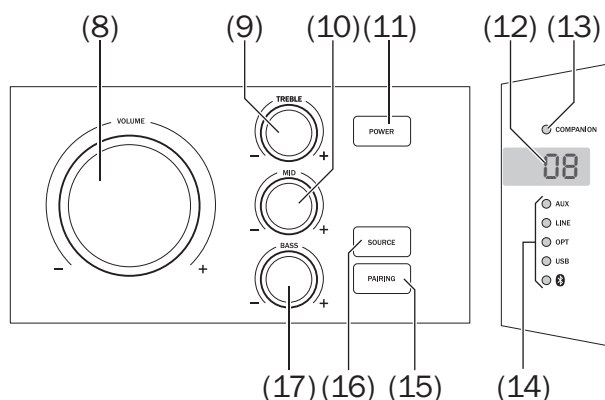

No.	Name	Function
(8)	VOLUME	Adjust the volume
(9)	TREBLE	Adjust the high range level
(10)	MID	Adjust the mid-range level
(11)	POWER	Switch the device on and to standby
(12)	DISPLAY	Display panel
(13)	COMPANION	Lights up during companion operation
(14)	AUX, LINE, OPT, USB, Bluetooth	Displays the active source
(15)	PAIRING	Start Bluetooth pairing
(16)	SOURCE	Select a source
(17)	BASS	Adjust the low-range level
(18)	LED	Power indicator (red LED)

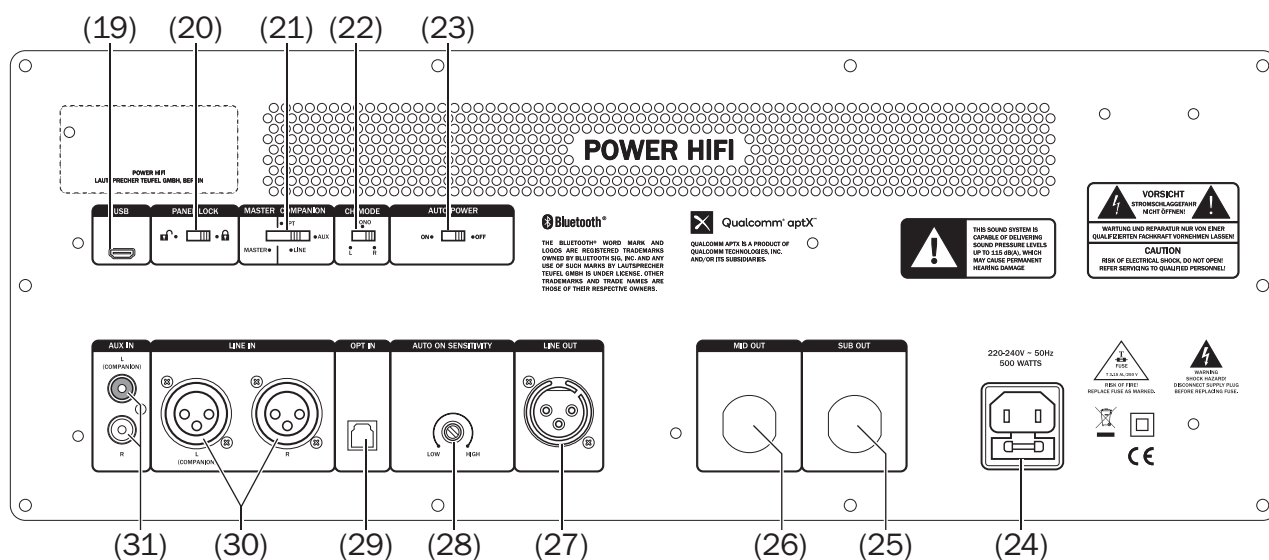
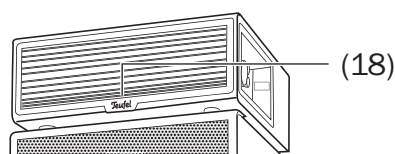

No.	Name	Function
(19)	USB SOUND	Micro-USB port to the PC for sound card operation and software updates
(20)	PANEL LOCK	Lock/unlock the control panel
(21)	MASTER/COMPANION	Switch between master/companion mode
(22)	CH MODE	Choose audio channel
(23)	AUTO POWER	Enable/disable automatic activation/deactivation
(24)	MAINS CONNECTION	Mains connection with glass tube fuse (3.15 AL)

No.	Name	Function
(25)	SUB OUT	Connector cord for bass speaker
(26)	MID OUT	Connector cord for mid-range speaker
(27)	LINE OUT	Analogue audio output (mono) for master/companion mode
(28)	SENSITIVITY	Set the level for automatic activation
(29)	OPT IN	Optical digital audio input
(30)	LINE IN	Analogue audio input
(31)	AUX IN	Analogue audio input

Remote Control

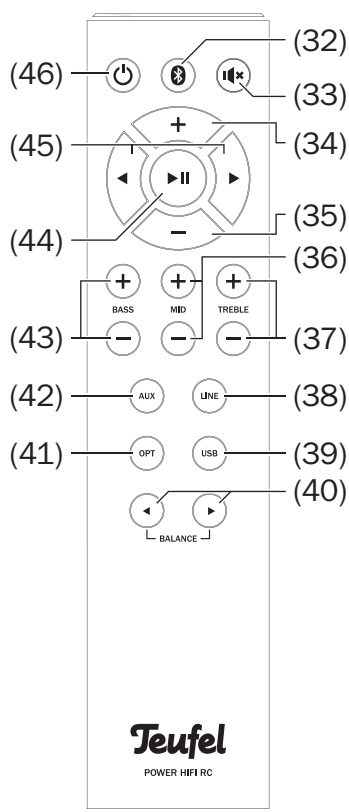

- (32)** Select Bluetooth® source, pushing and holding; Start pairing
- (33)** Mute on/off
- (34)** **+** Increase the volume
- (35)** **-** Reduce the volume
- (36)** **MID** Adjust the mid-range level
- (37)** **TREBLE** Adjust the high range level
- (38)** **LINE** Select LINE IN as the analogue source
- (39)** **USB** Select PC as the source via the sound card
- (40)** **BALANCE** Set the sound level ratio on the left/right
- (41)** **OPT** Select OPT IN as the digital source
- (42)** **AUX** Select analogue source AUX IN
- (43)** **BASS** Adjust the low-range level
- (44)** Start/pause playback
- (45)** Skip track forward/back
- (46)** Switch the device on and to standby
Pushing and holding forces the device to switch to standby (useful with multiple POWER HIFI).

Inserting/changing the batteries

The remote control is powered by 2 type AAA batteries.

1. To open the battery compartment, carefully unscrew the lid off – it is slightly under tension from the springs.
2. If applicable, remove the old batteries and dispose of them in an environmentally-friendly manner.
3. Slide the new batteries into the battery compartment according to the image on the back of the remote control.
4. Screw the lid back closed – it only fits the right way around and is slightly under tension from the springs.

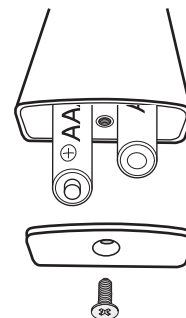

NOTICE

When inserting the batteries in the compartment, make sure that the polarity is correct.

CAUTION

Batteries can explode if handled improperly.

- Never attempt to recharge batteries.
- Only use batteries of the same or equivalent type.
- You must not heat, short circuit batteries and rechargeable batteries, dispose of them in fire or expose them to direct sunlight.
- Leaking battery acid may lead to chemical burns.
- Do not allow battery acid to come into contact with skin, eyes or mucous membranes. In the event of contact with acid, immediately flush the applicable areas with plenty of clean water and consult a physician if necessary.

i You can find comprehensive notes and tips for correct setup on our website.

Setup location

⚠ CAUTION

The total system weighs 60 kg.

- Make sure that the floor has the required load-bearing capacity.
- Only carry/transport the individual components – **never** the entire system stacked on top of one another.

NOTICE

Risk of damage! The isolation pads can produce discolouration on sensitive surfaces.

- On parquet, varnished wood and similar surfaces, you should stick felt gliders to the rubber feet of the speakers or put blankets or small carpets under them. This will prevent discolouration of the floor over the long term.
- Select a stable, level base.
- Make sure that the environment is clean and free from dust.
- Ensure sufficient ventilation.
- Select a location away from heat sources and prolonged exposure to direct sunlight.
- Always place the components on top of one another in this order: Bass speaker on the bottom, then the mid-range speaker and the high-range speaker with the control unit on the top.
- Make sure that the feet of the top components are positioned directly in the recesses in the underlying housing.
- Lay the connector cords so that they do not pose a tripping hazard.
- Do not place any heavy objects on the cables or the speakers.
- Do not place open flames such as burning candles or similar on the speakers.
- Do not place any containers with liquids such as vases, beverages or similar on the speakers.

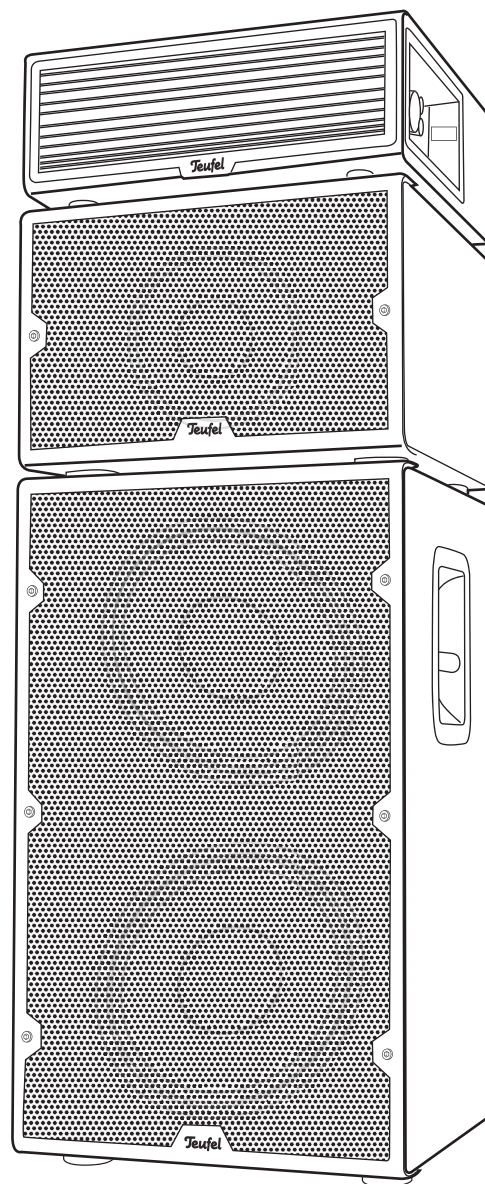

- Depending on the set-up location, it may make sense to angle the speakers towards the listening position. You should definitely try this to determine whether it noticeably improves the sound.

Connecting

⚠ CAUTION

- Observe the volume of the master device and the external player: With the Power Hifi Companion, large input signals will result in very high output volumes!
- Before switching it on, make sure that the MASTER/COMPANION switch is set to the desired position (be absolutely sure to refer to „Mode“ on page 17).

⚠ CAUTION

Risk of injury/damage!

- Lay all cables so that they do not pose a tripping hazard.

Connecting the speakers

The speaker connections from the control unit to the two speakers (25) and (26) are designed as 4-pole SpeakON plug connectors. The different cable lengths ensure that the cables cannot be mixed up.

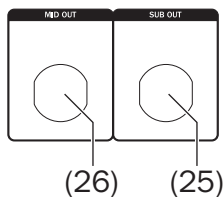

Insertion:

1. Hold the plug with the cable up in front of the jack.
2. Turn the plug approx. 45° to the left so its pivots fit into the jack.
3. Slide the plug all the way into the jack.
4. Turn the plug approx. 45° to the right until the locking mechanism clicks into place. The cable is now pointing up.

Disconnection:

1. Pull the chromed latch back and turn the plug approx. 45° to the left.
2. Pull the plug out of the jack.

Inputs for source devices

Analogue sources LINE IN, AUX IN

You can connect a source device with analogue sound (e.g. a CD player, a mixing console or a TV set) to each of the XLR jacks LINE IN (30) and the RCA jacks AUX IN (31).

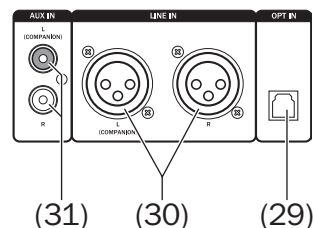

Digital source

You can connect the optical digital audio output of a source device to the OPTICAL jack (29). You will need an optical cable with a TOSLINK plug for this. Your source device requires either an optical 3.5 mm plug or also a TOSLINK plug.

In companion mode, the optimal input is intended for applications in connection with professional sound projection technology (see „Mode“ on page 17).

USB Sound Card

The POWER HIFI features an integrated USB sound card for audio output from a PC. To do so, connect the PC to the USB jack (19) via a USB cable (USB A to Micro B). You can find information about playback from the PC in „USB Sound Card“ on page 24.



Via this USB jack, you can also load software updates to your POWER HIFI (see „Software Update“ on page 26).

Output for companion mode

The analogue output LINE OUT **(27)** is especially designed for companion mode: The stereo channel, which this POWER HIFI **does not** play back is relayed here.

You can connect a second POWER HIFI here with the optional XLR connector cord (see „Mode“ on page 17).

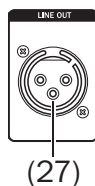

Mains connection

1. Insert the IEC power plug of the mains cord **(5)** into the jack **(24)**.
2. Insert the mains plug in a mains power socket (220–240 V~/50 Hz).

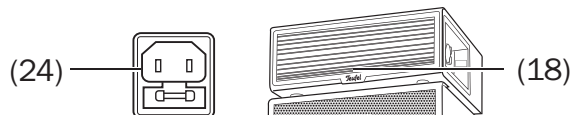

The power indicator **(18)** lights up continuously in a dim red on the front side and thus indicates the standby mode.

Operation

Activating and deactivating

- By pressing the Power button **(11)** or **(46)**, you switch the POWER HIFI on.
After switching the device on in master mode, the last active audio source and volume will be set (max. 25).
The power indicator **(18)** goes out, the LED **(14)** for the active source will light up and the display panel **(12)** will show the volume within a range from 0-100.
- By pressing the Power button **(11)** or **(46)** again, you switch the POWER HIFI to standby. The power indicator **(18)** is illuminated in a dim red now.
- By pushing and holding the button **(46)**, you also securely switch multiple POWER HIFI to standby. This is particularly useful in master/companion mode: Hold the button down and target the POWER HIFI one after another. They will then switch off.

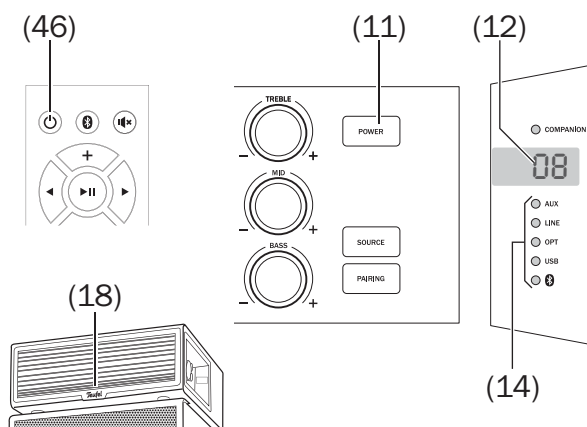

Automatic activation/deactivation

You can enable automatic activation and deactivation with the AUTO POWER switch **(23)**:

OFF – automatic disabled

ON – automatic enabled

- If the POWER HIFI does not receive an audio signal and if there is no operation for more than 20 minutes, it will automatically switch to standby.
- As soon as a signal is detected on an audio source, the POWER HIFI will also wake up and switch to the detected audio source.

With the AUTO ON SENSITIVITY control **(28)**, you can adjust the sensitivity from which the activation function is to recognise an audio signal:

- **LOW:** The sensitivity is set to low. Thus, an input signal is only considered at high input levels and the POWER HIFI will wake up.
- **HIGH:** The sensitivity is set to high. Thus, an input signal is already considered at low input levels and the POWER HIFI will wake up.

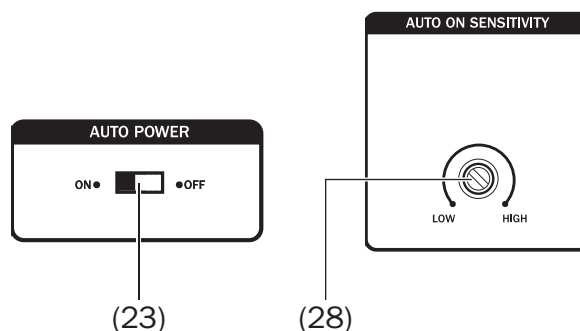

Selecting a source

On the control panel, switch the sources by pushing the SOURCE button (16).

On the remote control, select the sources with the following buttons:

Button	Connection
(32)	Bluetooth
LINE (38)	LINE IN (30)
USB (39)	USB (19)
OPT (41)	OPT IN (29)
AUX (42)	AUX IN (31)

The selected source is indicated by one of the LED (14).

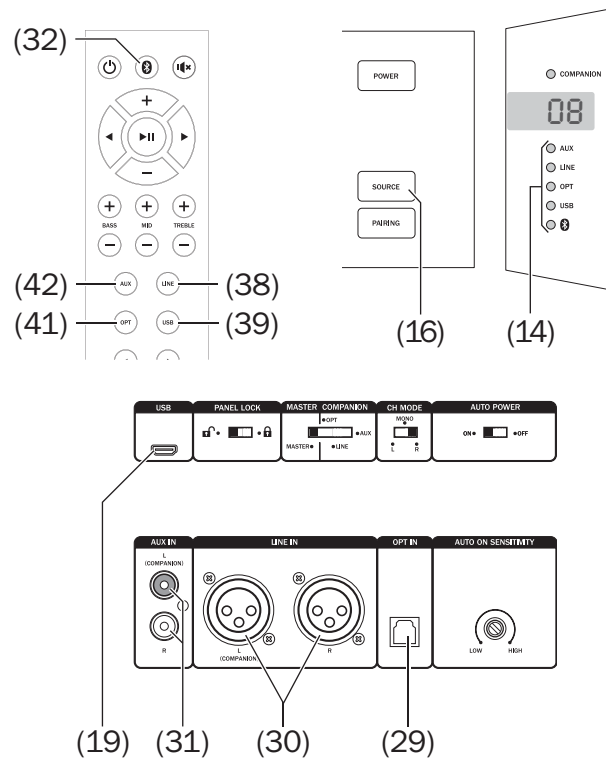

Adjusting the volume

- Increase the volume: Turn the VOLUME control (8) to the right or push the + button (34).
- Decrease the volume: Turn the VOLUME control (8) to the left or push the - button (35).
- If you turn the VOLUME control (8) quickly by more than 45°, the volume will increase or decrease quickly.
- Pushing the - button (35) longer will quickly decrease the volume.

The current volume level is shown from 0–100 on the display panel (12).

i The volume setting of an external player often affects the volume of the POWER HIFI.

Mute

- By pressing the button (33), (34) or (35), you can switch the sound off and back on. A zero ("0") will appear on the display panel (12) during muting.
- You can also activate the sound by adjusting the volume.

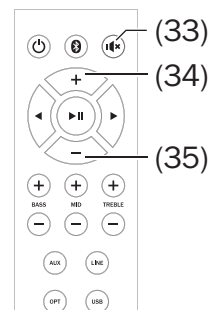
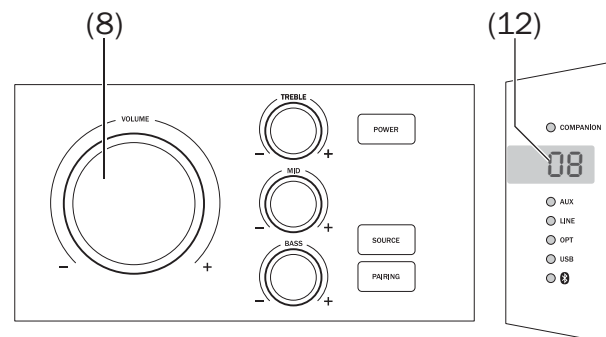

Balance

The BALANCE buttons ◀▶ (40) are used to set the volume level ratio between the left and right stereo channel.

The display panel (12) will indicate a shift to the left as a negative value and a shift to the right as a positive value.

This setting is not possible in mono mode (see below).

If power is lost or the stereo channel changes (see below), this setting is deleted.

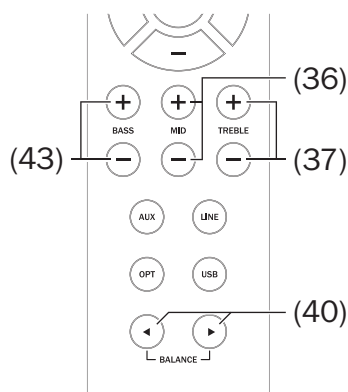

Adjusting the sound

You can adjust the sound in three frequency ranges:

- **BASS** – low tones, set with the BASS +/- buttons (43) or the BASS control (17).
 - **MID** – mid-range tones, set with the MID +/- buttons (36) or the MID control (10).
 - **TREBLE** – high-range tones, set with the TREBLE +/- buttons (37) or the TREBLE control (9).
- Possible settings: From “-6” (decrease) to “+6” (increase).

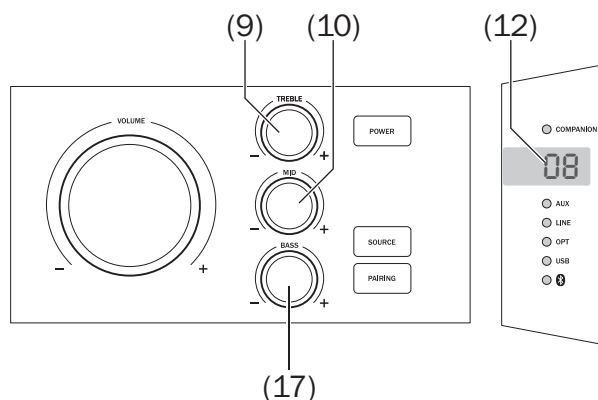

Setting the stereo channel

With the CH MODE switch (22), you determine the stereo channel, which is played back by this POWER HIFI.

- L – left channel
- MONO – both channels are mixed together
- R – right channel

The respective other channel is available via the output LINE OUT (27), with “MONO” the mixed signal.

Switching during operation will reset the balance setting (see above) to “0”.

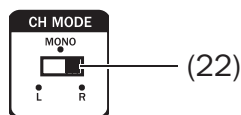

Locking the control panel

To avoid inadvertent or unauthorised operation, you can lock the display panel with the PANEL LOCK switch (20): The buttons and the controls are inoperable in the “” position – operation is only possible with the remote control.

To unlock the control panel, slide the switch to the “” position.

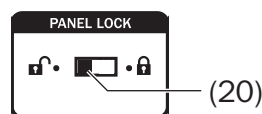

Mode

Set the mode of the POWER HIFI with the MASTER/COMPANION switch **(21)**:

MASTER

- All inputs, buttons and controls are active.
- The stereo channel set with CH MODE (see “Setting the stereo channel” on page 16) is played back; the respective other channel is available on the output LINE OUT **(27)**.

⚠ CAUTION

- Observe the volume of the master device and the external player: With the Power Hifi Companion, large input signals will result in very high output volumes!

COMPANION

Companion operation is activated when the MASTER/COMPANION switch **(21)** is set to the following settings:

- **OPT** digital input OPT IN **(29)** With this input, you can select the stereo channel (L/R) for playback with the CH MODE switch **(22)**.
- **LINE** analogue input LINE IN **(30)** Only the “L (COMPANION)” jack is active.
- **AUX** analogue mono input AUX IN **(31)** . Only the “L (COMPANION)” jack is active.
- The selected input is limited to a volume of 0 in the first configuration and must be manually set to 100. All other inputs are inoperable.
- The COMPANION LED **(13)** lights up as well as the LED **(14)** for the selected source.

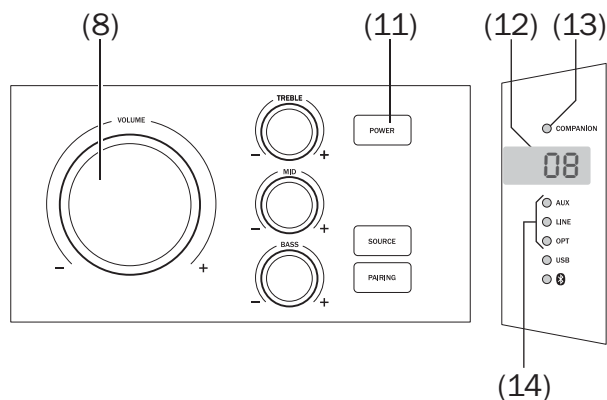
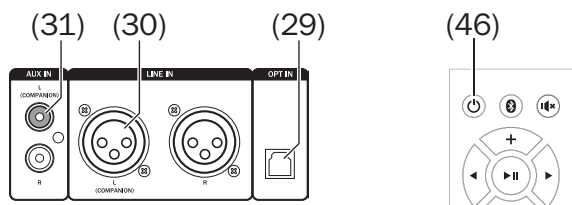
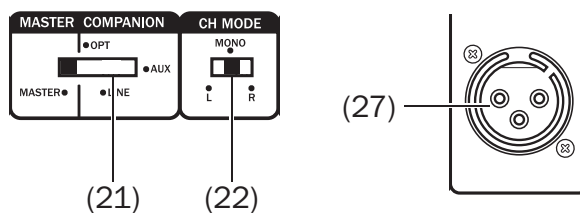

- The power buttons **(11)** and **(46)** as well as the VOLUME control **(8)** work.
- All other buttons and controls are inactive; when operated, only the COMPANION LED **(13)** will blink briefly.

After the entire system is connected and switched on, each companion will display a pulsating plug sign in front of the “+0” volume display. In so doing, the companion indicates that its volume is set to the safety level.

- On the companion, carefully turn the volume to maximum (level of 100) with the VOLUME control **(8)**.

This is the only way to correctly control the entire volume from the master. Otherwise, the balance between the left and right channel will not be correct. After initial setting of the volume, the companion will only display three dashes on the display panel.

CAUTION

Risk of injury/damage!

- Once the volume on the companion has been set, a very high playback level can be reached.

If a POWER HIFI is operated as a companion, you can decrease the volume with respect to the source with the VOLUME control **(8)**. However, the maximum volume is controlled on the source.

- The recently set volume on the companion will be saved after approx. 30 seconds of operation and restored after standby.
- When disconnected from the power supply or when the MASTER/COMPANION switch **(21)** is operated, the volume will be set to 25 for the purpose of safety.

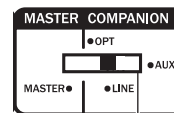
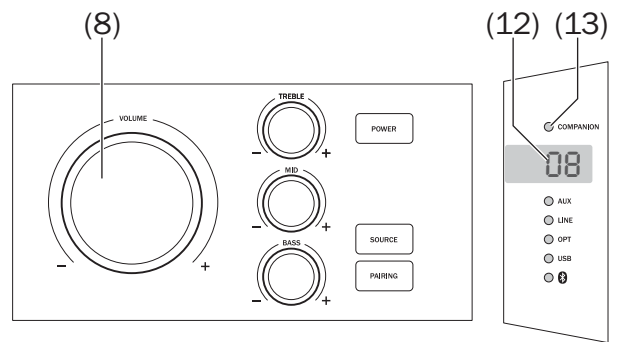

(21)

Example for a mono setup

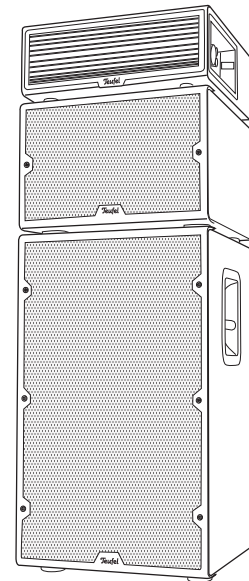
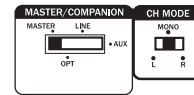

POWER HIFI
Mono Master

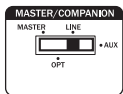

Example for a stereo setup

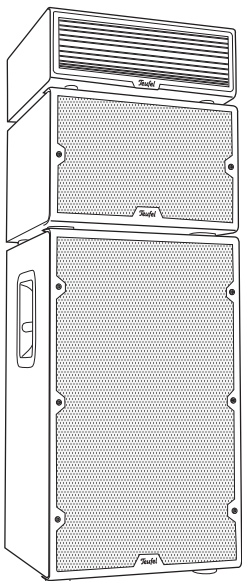
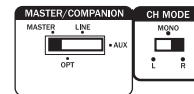

POWER HIFI
Stereo Companion

All inputs can be used on the master. Operation occurs via the control panel or the remote control for the master.

The MASTER/COMPANION switch is set to MASTER on the master and to LINE on the companion.

The master is set to the right stereo channel with the CH MODE switch and it passes the left channel to the companion via the XLR cable. The position of this switch is ignored on the companion.

The master's output LINE OUT is connected to the companion's input LINE IN L via XLR cable.

Once the volume on the companion has been initially set, the volume and sound on the master will be controlled.

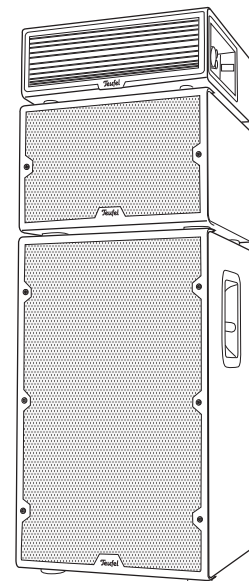
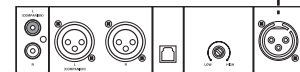

POWER HIFI
Stereo Master

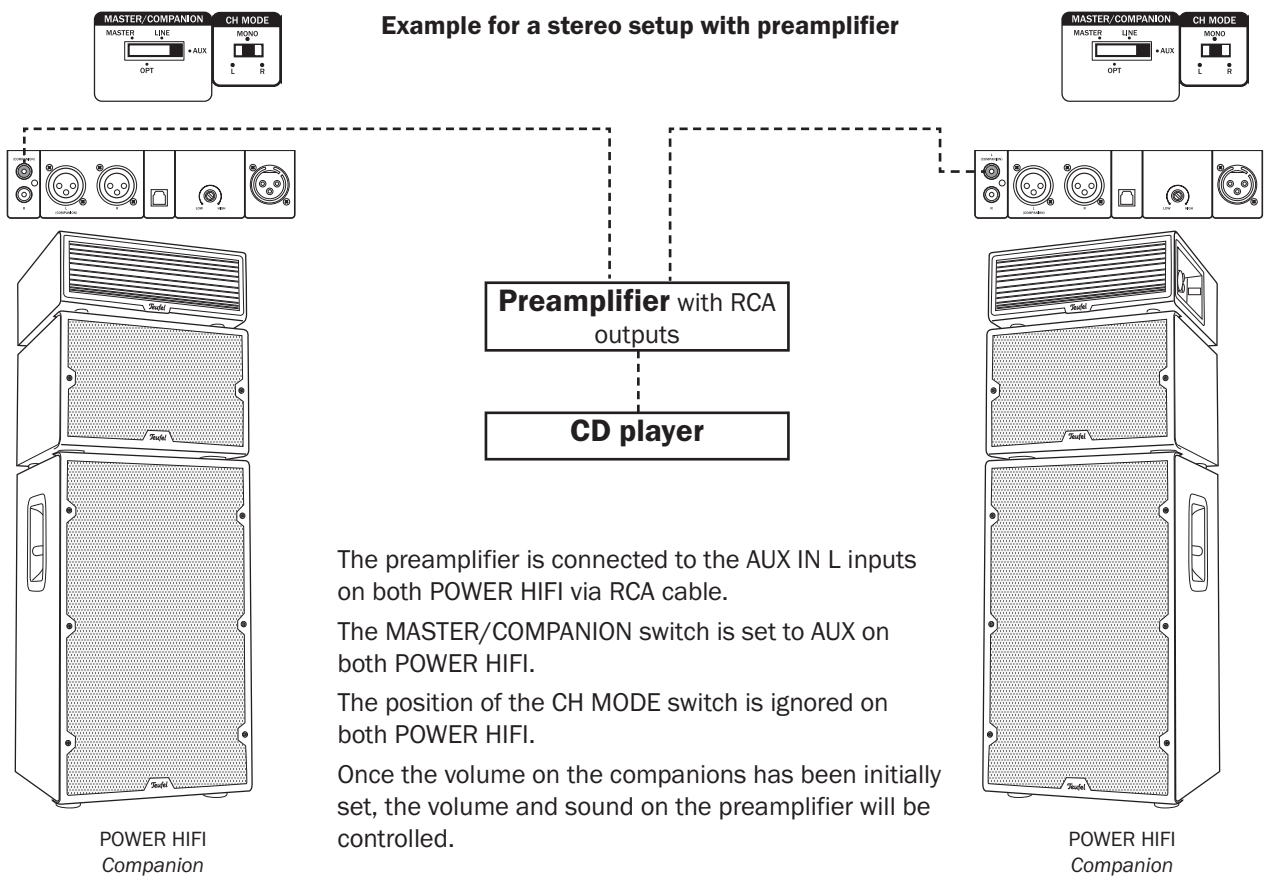
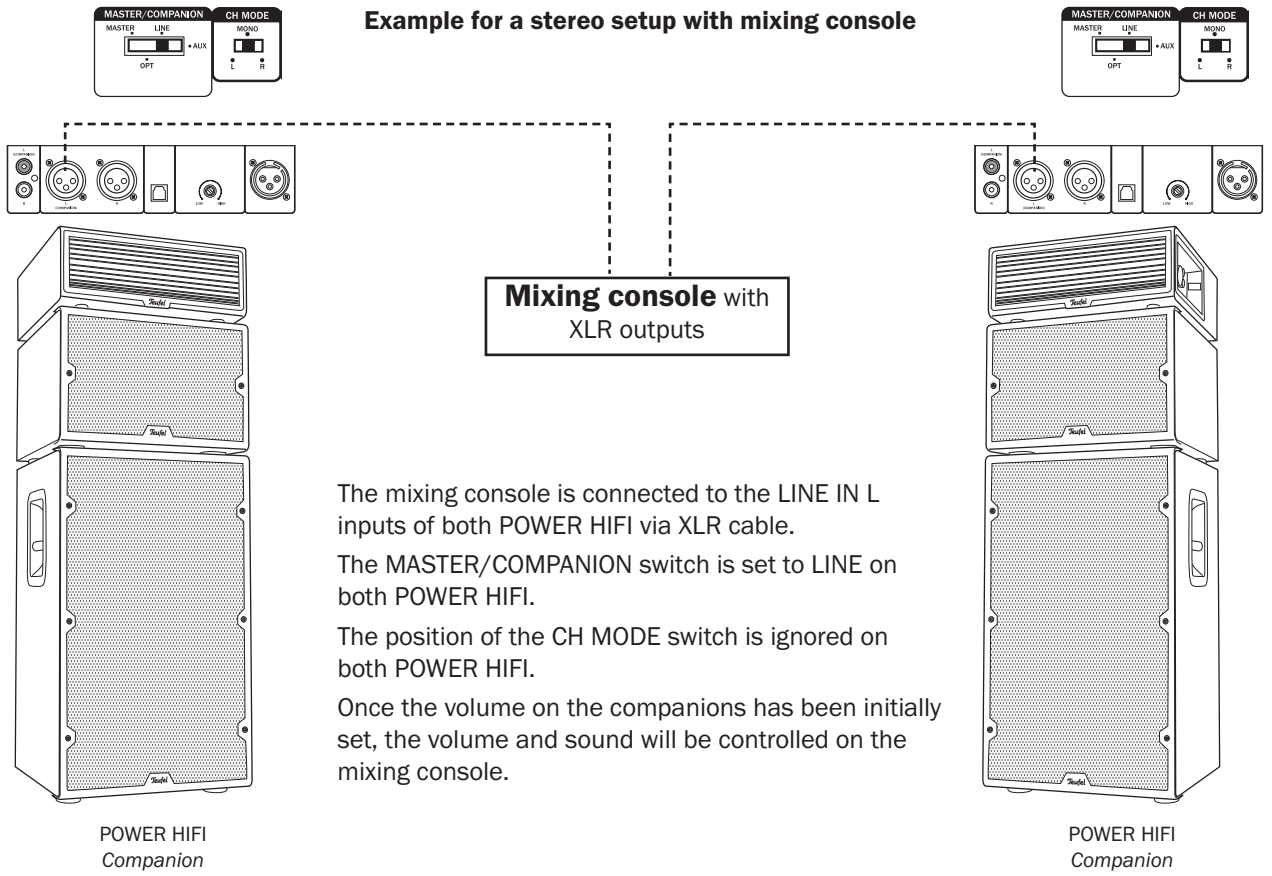

Example for a mono cascade

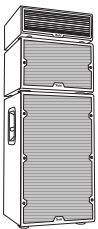
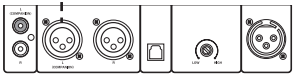
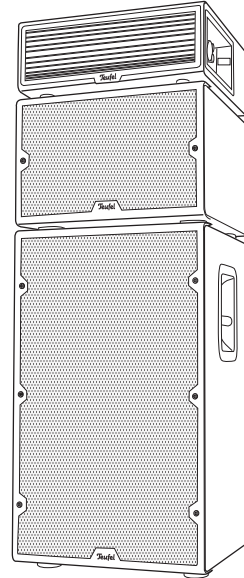
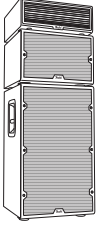
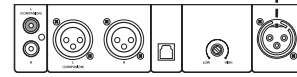
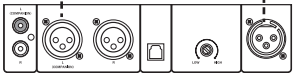
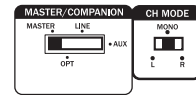
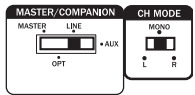

All inputs can be used on the master. Operation occurs via the control panel or the remote control for the master.

The MASTER/COMPANION switch is set to MASTER on the master and to LINE on all companions.

The master is set to MONO with the CH MODE switch and it passes the mixed stereo signal to the first companion via the XLR cable. The position of these switches will be ignored on all companions.

The master's LINE OUT output is connected to the first companion's LINE IN L input via XLR cable. The first companion's LINE OUT output is connected to the LINE IN L input of the next companion and so on. This way, up to four companions can be connected in a cascade.

Once the volume on the companions has been initially set, the volume and sound on the master will be controlled. However, the volume of the companions can be reduced via the master if, for example, the dance area is to be supplied with louder sound than the back part of the room.

One to three
POWER HIFI
Mono Companion

POWER HIFI
Mono Master

Bluetooth® Mode

Via Bluetooth®, you can connect a compatible external player wirelessly to the POWER HIFI. The audio output of your external player is then emitted via the POWER HIFI.

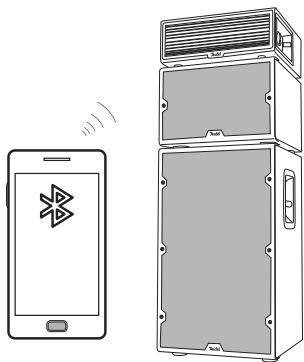

The Bluetooth® wireless transmission system has a range of approximately 10 metres that is limited by walls and furnishings. If the connection is cut off, the POWER HIFI will attempt to re-establish a connection until you select another source.

You can also register two Bluetooth devices and have them played in alternation.

NOTICE

Only use the Bluetooth® function in locations where wireless radio transmission is allowed.

Please keep in mind that the Bluetooth® behaviour may differ depending on the external player's operating system.

Bluetooth® options

Depending on the device type, your external player (e.g. smartphone) may also have a menu for Bluetooth® options such as media playback. You can find more information about the Bluetooth® options in the instruction manual for your external player/smartphone.

Bluetooth® pairing

To play the audio of your external player on your POWER HIFI via Bluetooth®, you must first connect the devices with each other. The technical term for this is “pairing”.

1. Activate the Bluetooth® function on your external player (e.g. smartphone).

2. Select the “Bluetooth” input on the POWER HIFI. For this, push the button **(32)** or, if applicable, push the SOURCE button **(16)** multiple times until the LED **(14)** illuminates in blue.
3. If the POWER HIFI is not connected to an external player, pairing will start automatically and the LED **(14)** will quickly flash blue. Otherwise, push the button **(32)** and hold it down for approx. 2 seconds or briefly push the PAIRING button **(15)** to start pairing. Pairing will be active for approx. 60 seconds. Afterwards, the LED **(14)** will blink slowly. This indicates that there is no connection.
4. Let your external player scan for Bluetooth® devices. You will find more information about this in the user manual of your external player. After the search run, the “POWER HIFI” should also be present in the list of detected devices.
5. Select “POWER HIFI” from the list of detected devices.
6. If your external player asks for a code, enter “0000” (four zeros). Pairing is now complete and your POWER HIFI will now act as a Bluetooth® playback device. The POWER HIFI will now play back all sounds that would otherwise be played by your external player/smartphone.
7. If you would like to pair a second external player, repeat the above steps with the second device. Then select the POWER HIFI again from the list of paired devices on the first device. Now you can use both devices in party mode in alternation.

Restoring the connection with a paired external player

If your POWER HIFI was previously connected to the external player, it is no longer necessary to switch it to pairing mode to connect again. Simply selecting “POWER HIFI” on your external player from the list of paired devices is enough.

The POWER HIFI stores the pairing data of the last 7 external players (max.) which were connected to the system.

- To delete the list of external players, push the **(32)** button for 10 seconds. External players can then only establish a connection after re-pairing.

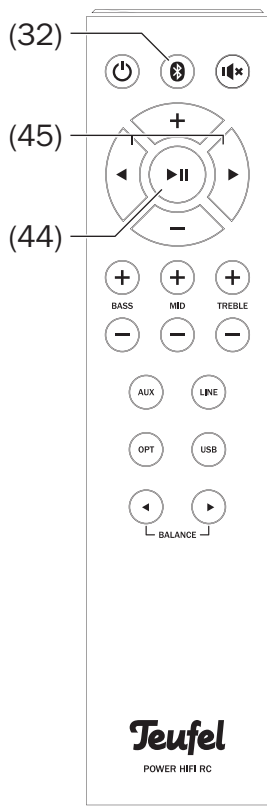
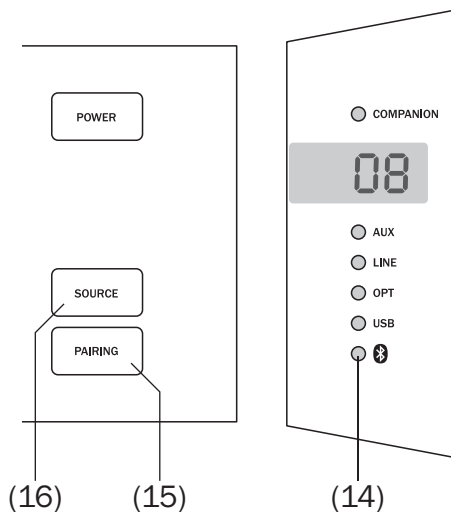

Interruption of connection

If your external player moves out of the range of your POWER HIFI, the Bluetooth® connection will be interrupted. The connection will be re-established automatically when you are back within range.

Playback

i The volume and sound settings of the external player also affect the volume and the sound of the POWER HIFI.

1. Select the “Bluetooth” input on the POWER HIFI.
For this, tap the button **(32)**, or, if applicable, the SOURCE button **(16)** multiple times until the LED **(14)** illuminates in blue.
2. On your external player, switch the Bluetooth® function on and select “POWER HIFI” as the playback device.
3. Start and control the playback on your source device.

Depending on the source device, you can also control playback with the remote control of the POWER HIFI:

- Play next track: Tap the navigation button **(45)**.
- Play the track or chapter from the beginning: Briefly tap the navigation button **(45)**.
- Play the previous track or previous chapter: Briefly tap the navigation buttons **(45)** twice.
- Pause/continue playback: Push the button **(44)**.

If your source device is a smartphone, the Bluetooth® connection will be interrupted in the event of an incoming call and you can make phone calls as usual. After finishing your phone call, the sounds will once again be diverted and played back by your POWER HIFI.

Party mode

If you are using two external players at the same time, you can look for the next track on one device while the other is playing. Once the track is over, push the stop or pause button and start playback on the other device.

Terminating the connection

To terminate the Bluetooth® connection, switch the Bluetooth® function on your external player/smartphone off.

USB Sound Card

The POWER HIFI features an integrated USB sound card for audio output from a PC.

No driver software is required for playback from the PC under Windows 7, 8 and 10 as well as Mac OS X 10.5 and higher. The operating systems detect the POWER HIFI as a USB Advanced Audio Device when it is connected to the USB port.

Connect the USB micro port (19) to a USB port (19) on your PC. For this, you can use any type A USB 2.0 adapter cable to micro B.



Mac OS X

To quickly switch playback to the POWER HIFI, push the [alt] button on the Mac and click the speaker icon on the menu bar (you can enable this icon under “Sound” in the system preferences, see below). Select the “PowerHIFI” from the list under “Output device”. All Mac sounds will now be played back via the POWER HIFI.



“Sound” system preference

In the “Sound” system preference, you can select the POWER HIFI as the playback device on the “Output” tab: In the list, click “PowerHIFI”. All Mac sounds will now be played back via the POWER HIFI.

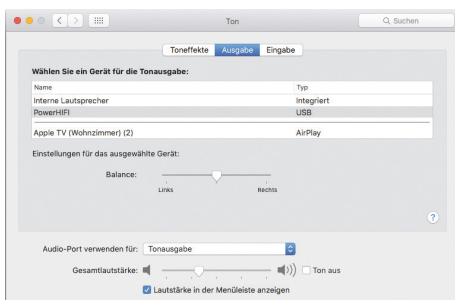

If you check “Display volume on the menu bar” at the very bottom, you can also access the menu described above via the speaker icon.

Further sound settings depend on the programme in use, e.g. iTunes or Facetime.

Windows 7, 8 and 10:

When establishing the USB connection, Windows automatically detects the POWER HIFI and allocates playback accordingly.

To quickly switch between the playback devices, right click the speaker icon on the task bar and select “Playback devices”. The corresponding “Sound” tab of the control panel will open.

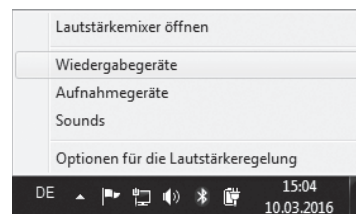

“Sound” control panel

In the “Sound” control panel, you can select the POWER HIFI as the playback device on the “Playback” tab: In the list, click “Speaker” under “PowerHIFI”. All PC sounds will now be played back via the POWER HIFI.

If you want the audio output to permanently occur via the POWER HIFI (also after rebooting the PC), click the button “As Standard”.

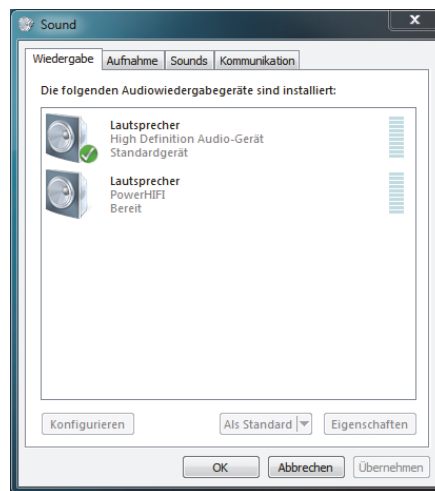

Other sound settings depend on the programme being used, e.g. Media Center or Skype.

Playback

i The volume and sound settings of the PC also affect the volume and the sound of the POWER HIFI.

1. Select the “USB” input on the POWER HIFI. For this, briefly push the USB button **(39)**, or, if applicable, the SOURCE button **(16)** multiple times until the USB LED **(14)** illuminates in red.
2. Select “PowerHIFI” as a playback device on your PC.
3. Start and control the playback on your PC.

You can also control playback with the remote control of the POWER HIFI:

- Play next track: Tap the navigation button **▶ (45)**.
- Play the track or chapter from the beginning: Briefly tap the navigation button **◀ (45)**.
- Play the previous track or previous chapter: Briefly tap the navigation buttons **◀ (45)** twice.
- Pause/continue playback: Push the button **▶ || (44)**.

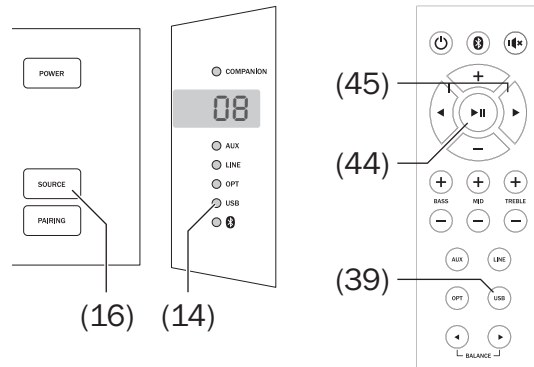

Software Update

The software of the POWER HIFI is being continually developed. You can download subsequent versions from our website.

Installing new software

1. Load the new software from our website.
2. Unpack the downloaded file.
3. Pull the mains plug of the POWER HIFI and wait until the power indicator **(18)** is off.
4. With a USB cable, connect your PC or Mac to the USB jack **(19)** of the POWER HIFI.
5. Push and hold the buttons POWER **(11)** and SOURCE **(16)** at the same time and insert the mains plug of the POWER HIFI back into the socket. Continue to hold the buttons down until the power indicator **(18)** blinks rhythmically.
6. A USB drive "POWER HIFI" will be displayed on your PC now. There, you will see a file "version.txt", from which you can determine the currently installed version.
7. At this point, you can still cancel the update without risk by interrupting the USB connection to the PC.

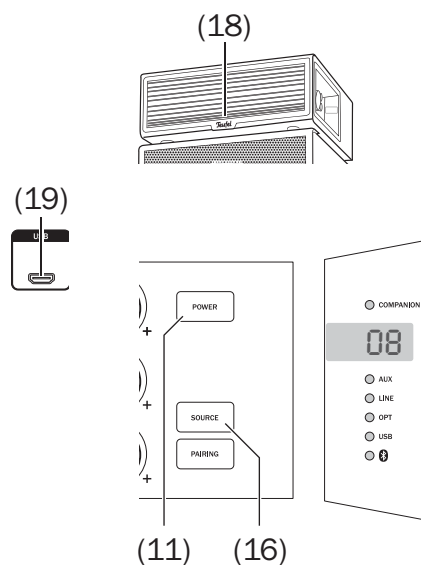

NOTICE

Risk of damage!

– During the following steps, the POWER HIFI must not be switched off and the USB connection must not be interrupted!

8. Copy the unpacked update file on your PC to the "POWER HIFI" drive.
The update will now run automatically. The power indicator **(18)** will continue to blink rhythmically.
9. Once the update is complete, the POWER HIFI will switch to standby.
At the same time, the USB connection to the PC will be interrupted, which may cause an error message on the PC. Ignore this message if applicable.
10. Pull the mains plug of the POWER HIFI again and wait until the power indicator **(18)** is off.
11. Connect the POWER HIFI to the power supply again.

The new software was installed.

NOTICE

External influences could damage the speakers.

- *If possible, only use plain water without any additives. In case of stubborn marks, a mild soap solution may be used.*
 - *Do not use caustic cleaning products, white spirit, thinners, petrol or similar under any circumstances. Such cleaning agents may damage the delicate surface of the housing.*
- Ideally, you should remove dust or small amounts of dirt with a dry, smooth leather cloth.
 - Use a damp cloth to rub off stubborn dirt. Make sure that no liquid penetrates the housing.
 - Then immediately wipe the damp surfaces off with a soft cloth without applying pressure.

Troubleshooting

The following advice should help you to solve problems. If this does not help, you will find useful information in the detailed FAQs on our website. Otherwise, please contact our hotline (see page 3). Take note of the warranty instructions.

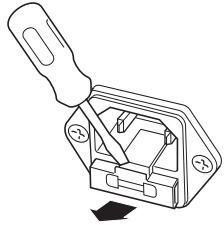
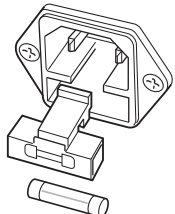
Problem	Possible cause	Solution
No function.	No power supply.	Check the function of the socket with another device.
	Control panel locked.	To unlock the control panel, slide the PANEL LOCK switch (20) to the “  ” position.
	Mains fuse defective	<div style="display: flex; justify-content: space-around;"> <div style="text-align: center;"> <p>1.</p>  <p>Disconnect the mains cord. Carefully pull the fuse holder on the mains connection jack out.</p> </div> <div style="text-align: center;"> <p>2.</p>  <p>Push the old fuse down and out. Insert a new fuse (3.15 A delayed action) and push the holder back.</p> </div> </div>
No sound.	The wrong source has been selected.	Select the correct source (see “Selecting a source” on page 15).
	The volume has been set too low.	Carefully increase the volume.
	The volume of the external player has been set too low.	Carefully increase the volume of the external player.
	Speaker cable not connected.	Properly connect the speaker (page 12).
No sound with Bluetooth®.	No Bluetooth® connection.	Establish a connection (see page „Bluetooth® pairing“ on page 22).
	POWER HIFI has not been selected as the output device.	On the external player, select “POWER HIFI” as the Bluetooth® output device.
	Bluetooth® connection impaired by another radio system (e.g. cordless telephone, Wi-Fi).	Set up the POWER HIFI and/or external player in another location. Move to another room to test.
	With some smartphones, switching to another app may result in no sound being emitted in the new app.	Before switching between apps, pause the previously used app to prevent this from happening.
No sound via cable (LINE, AUX).	Volume of the playback program has been set to zero.	Carefully increase the volume on the source device.
The balance is incorrect in master-companion mode.	The volume on the companion has been set too low.	Carefully set the companion’s volume to 100 with the (8) control.

A hum is emitted from the speaker.	The POWER HIFI is connected to a different power circuit than the rest of the system.	Connect the POWER HIFI and source device/preamplifier to the same power circuit.
	The hum is due to line disturbance.	Buy a line filter and connect all devices to it.
	The humming is caused by a multiple socket strip.	Use a different multiple socket strip or connect the POWER HIFI directly to the wall socket.

Technical Data

Bass speaker	
Dimensions (W × H × D)	440 × 760 (thereof attributed to the feet: 15 mm) × 400
Weight	38.2 kg
Mid-range speaker	
Dimensions (W × H × D)	440 × 300 (thereof attributed to the feet: 15 mm) × 400
Weight	13.2 kg
High-range speaker with control unit	
Dimensions (W × H × D)	440 × 200 (thereof attributed to the feet: 15 mm) × 400
Weight	9.1 kg
Operating voltage	220–240 V~, 50 Hz
Max. power consumption	500 watts

The following radio frequency bands and radio transmitting powers are used in this product:

Radio network	Frequency bands in MHz	Transmission power in mW/dBm
Bluetooth	2400–2483.5	2.5/4

You can find further technical data on our website.

Technical changes reserved!

Lautsprecher Teufel GmbH hereby declares that the “POWER HIFI” radio system complies with the Directives 2014/53/EU, 2014/30/EU and 2014/35/EU. The full text of the EU declaration of conformity is available at the following Internet address:

www.teufelaudio.com/konformitaetserklaerungen.html

Teufel

Please contact our customer service department with any questions, suggestions, or complaints:

Lautsprecher Teufel GmbH
BIKINI Berlin
Budapester Str. 44
10787 Berlin (Germany)

Telephone: 00800 200 300 40 (toll-free)

Fax: +49 (0)30 / 300 930 930

Online support: www.teufelaudio.com/service

Contact form: www.teufelaudio.com/contact

No responsibility is assumed for the correctness of this information.
Technical changes, typographical errors and other errors reserved.