

# Technical Description And User Manual

---

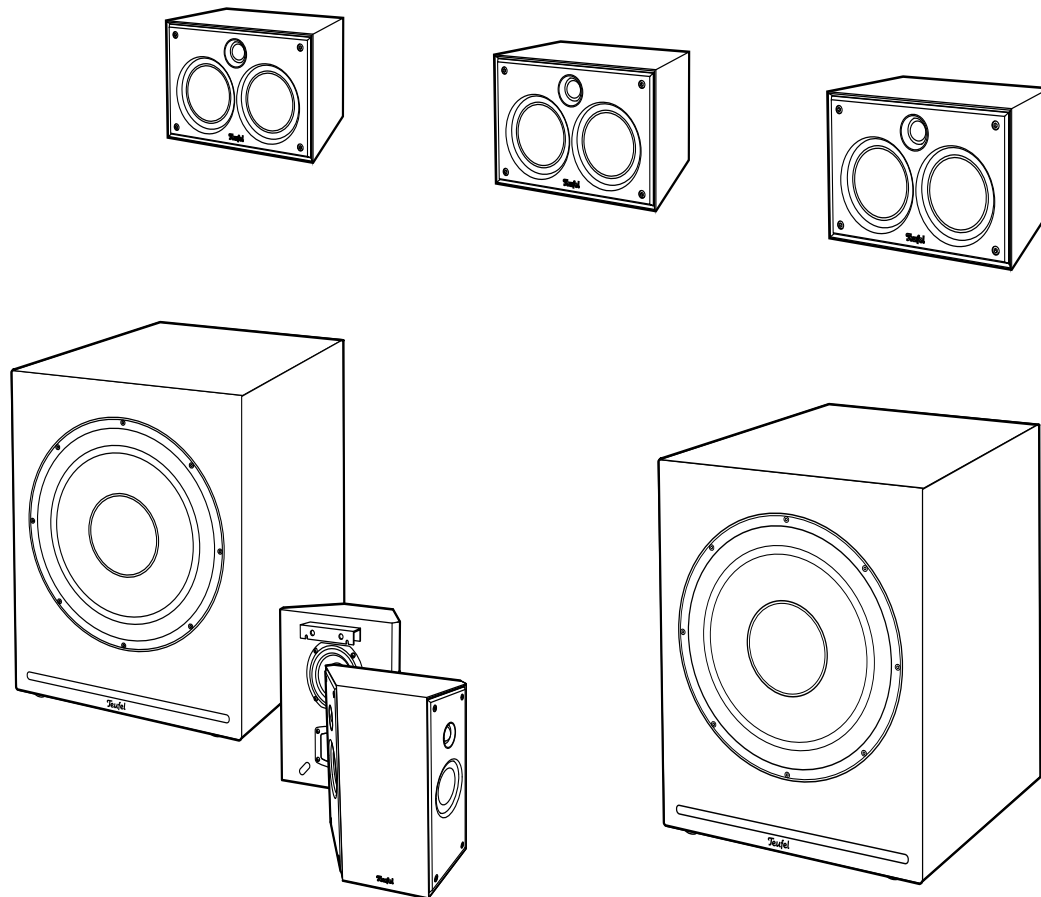

## System 6 THX<sup>®</sup> Select

5.2 speaker set with THX<sup>®</sup> select certificate

**Teufel**

# Contents

---

<b>General Notes And Information .....</b>	<b>3</b>	<b>Connecting.....</b>	<b>10</b>
Notice .....	3	Connecting the subwoofers .....	10
Trademarks .....	3	Connecting the speakers .....	10
Original packaging.....	3	<b>Settings.....</b>	<b>11</b>
Complaints.....	3	Adjusting the AV receiver and subwoofers .....	11
Contact.....	3	AV receiver settings.....	11
Proper use.....	3	Subwoofer settings.....	11
<b>For Your Safety .....</b>	<b>4</b>	Adjusting the volume.....	11
Signal terms.....	4	Configuring the sound pattern .....	11
Safety notes .....	4	<b>Care And Cleaning .....</b>	<b>12</b>
Warning of damage to property.....	5	<b>Troubleshooting .....</b>	<b>13</b>
<b>Overview .....</b>	<b>6</b>	<b>Technical Data .....</b>	<b>14</b>
Unpacking .....	6		
Package contents .....	6		
Checking the package contents .....	6		
<b>Assembly.....</b>	<b>7</b>		
Isolation pads .....	7		
Protective cover .....	7		
Optional metal grid.....	7		
<b>Setup/Wall Mounting .....</b>	<b>8</b>		
Setup location.....	8		
Location tips.....	8		
Setup .....	8		
Front speaker .....	8		
Center speaker.....	8		
Subwoofer .....	8		
Rear speakers .....	9		
Wall mounting.....	9		
Wall bracket/speaker stand.....	9		

# General Notes And Information

## Notice

The information in this document may change without prior notice and in no way constitutes any liability on the part of Lautsprecher Teufel GmbH.

No part of this user manual may be reproduced in any form or be broadcasted in any way electronically, mechanically, by photocopy or recording without the written permission of Lautsprecher Teufel GmbH.

© Lautsprecher Teufel GmbH

Version 1.0

March 2017

## Trademarks

® All trademarks are the property of their respective owners.



THX SELECT and the THX logo are trademarks of THX Ltd., which are registered in some jurisdictions. All rights reserved.

## Original packaging

If you wish to exercise your eight-week right of return, we ask that you be absolutely sure to hold onto the packaging. We can only accept the return of the speakers WITH THE ORIGINAL PACKAGING.

Empty boxes are not available!

## Complaints

In case of a complaint we will need the following information to process your enquiry:

### 1. Invoice number

Can be found on the sales slip (enclosed with the product) or on the order confirmation received as a PDF document, e.g. 4322543

### 2. Serial number or batch number

Located on the back side of the device, e.g. serial no.: KB20240129A-123.

Thank you for your support!

## Contact

Please contact our customer service with any questions, suggestions or criticism:

**Lautsprecher Teufel GmbH**

**BIKINI Berlin**

**Budapester Str. 44**

**10787 Berlin (Germany)**

Phone 00800 - 200 300 40 (toll-free)

Fax: +49 (0)30 / 300 930 930

Service: [www.teufelaudio.com/service](http://www.teufelaudio.com/service)

Contact: [www.teufelaudio.com/contact](http://www.teufelaudio.com/contact)

## Proper use

The speakers are designed for the playback of music and speech from an external player.

Only use the speakers as described in this user manual. Any other use will be deemed as not in accordance with the instructions and may lead to damage of property or even persons.

The manufacturer accepts no liability for damage caused by improper use.

The speakers are intended for domestic use only.



Before operating the speakers, please first carefully read the safety notes and user manual (also the separate ones for the subwoofers). This is the only way to use all functions safely and reliably. Store the user manuals in a safe place and also be sure to pass them on to any subsequent owner.

## NOTICE

***Check that all items have been delivered and that nothing is damaged. If you find any damage, do not operate the device; instead contact our customer service department.***

# For Your Safety

## Signal terms

You can find the following signal terms in this user manual:

### **WARNING**

*This signal term indicates a moderate risk, which, if not avoided, may result in death or severe injury.*

### **CAUTION**

*This signal term indicates a low risk, which, if not avoided, may result in minor or moderate injury.*

### **NOTICE**

*This signal term warns you of potential damage.*

## Safety notes

This chapter contains general safety notes which you should always observe to protect yourself and third parties. Also observe the warning notes in each chapter of this user manual.

### **An unsuitable setup location may result in injury and damage.**

- If the speakers are not securely mounted, do not use them in vehicles, in unstable locations, on wobbly tripods or furniture, on underdimensioned brackets etc. The speakers may tip or fall over and cause injury to persons or be damaged themselves.
- Place the speakers in such a way that they cannot be knocked over inadvertently and make sure that the cables do not pose a tripping hazard.
- Carefully follow the user manual, including those provided separately for the subwoofer.
- Make sure that the wall mounting is done in a professional manner.
- In case of a wall mounting, verify the carrying capacity of the walls and make sure that there are no cables or pipes in the drilling areas. Before you drill, use a metal detector to check the applicable areas. Otherwise, there is a risk of electric shock/short circuit!
- Do not place the speakers near heat sources (e.g. heaters, ovens, other heat generating equipment such as amplifiers etc.).

**An unstable base may cause the unit to tip and injure or even kill persons, children are particularly at risk. You can prevent a large number of accidents by taking the following precautions:**

- Only place the subwoofers on the floor.
- If you want to use underframes or speaker stands, only use those recommended by the manufacturer.
- When storing the product, also ensure that it stands safely and that it cannot be knocked down or over.

**Children can become trapped in the plastic wrapping when playing and suffocate.**

- Do not allow children to play with the device or the plastic wrapping. There is a danger of suffocation.
- Ensure that children do not remove small parts from the device or take them off of the device (e.g. control knobs or plug adapters). They could swallow the parts and choke.
- Never allow children to operate electrical equipment unsupervised.

### **CAUTION**



**Extended listening at high volumes may lead to hearing loss.**

- To avoid damage to health, avoid extended listening at high volumes.
- When the volume is set high, always keep a certain distance from the device and never place your ear directly on the speaker.
- If the AV receiver is set to full volume, it may produce very high sound pressure. This may have psychic consequences and also cause physical injury. Children and pets are particularly at risk. Set your signal source device volume control to a low setting before turning on the power.

**CAUTION**



*This product contains magnetic material.*

- Keep magnetically sensitive objects (e.g. credit cards etc.) away from the speakers.
- If necessary, consult your physician and ask for effects on implants such as pacemakers or defibrillators.

**Warning of damage to property**

**NOTICE**

*If the device is subjected to warm temperatures after being cold (e.g. after transport), condensation may occur inside of it.*

- In this case, wait at least 2 hours before you connect and activate it.

**Improper use may lead to damage or fire.**

- Do not place open flames such as burning candles or similar on the device.
- Ensure sufficient ventilation.
- Do not place the device in direct sunlight.
- Only use the device indoors.
- Do not operate the device in wet rooms and protect it from dripping and splashing water. Make sure that no vases or other liquid-filled objects are located on or near the device in order to prevent liquid from penetrating the housing.

**The isolation pads can produce discolouration on sensitive surfaces.**

- On parquet, varnished wood and similar surfaces, you should stick felt gliders to the rubber feet of the speakers or put blankets or small carpets under them. This will prevent discolouration of the floor over the long term.

# Overview

## Unpacking

The set is delivered in multiple boxes.

- Be absolutely sure to observe the separate user manuals for the subwoofers.
- Carefully open the boxes, take the EPE foam half-shells out and carefully lift the accessories and speakers out of the box.

## Package contents

- ① 2× active subwoofers S 6000 SW THX® Select with accessories
- ② 3× front speakers S 600 FCR THX® Select
- ③ 3× protective metal grids for ②, each with 4 screws and distance bushings
- ④ 4× self-adhesive isolation pads for ②.
- ⑤ 2× dipole speakers S 600 D THX® Select (one for left “L” and right “R” each)
- ⑥ 4× protective metal grids for ⑤, each with 4 screws and distance bushings

## Checking the package contents

- Check that all items have been delivered and that nothing is damaged.
- If the delivery is incomplete or exhibits transport damages, please contact our service team (see page 3).
- Do not in any case operate the device if it is damaged.

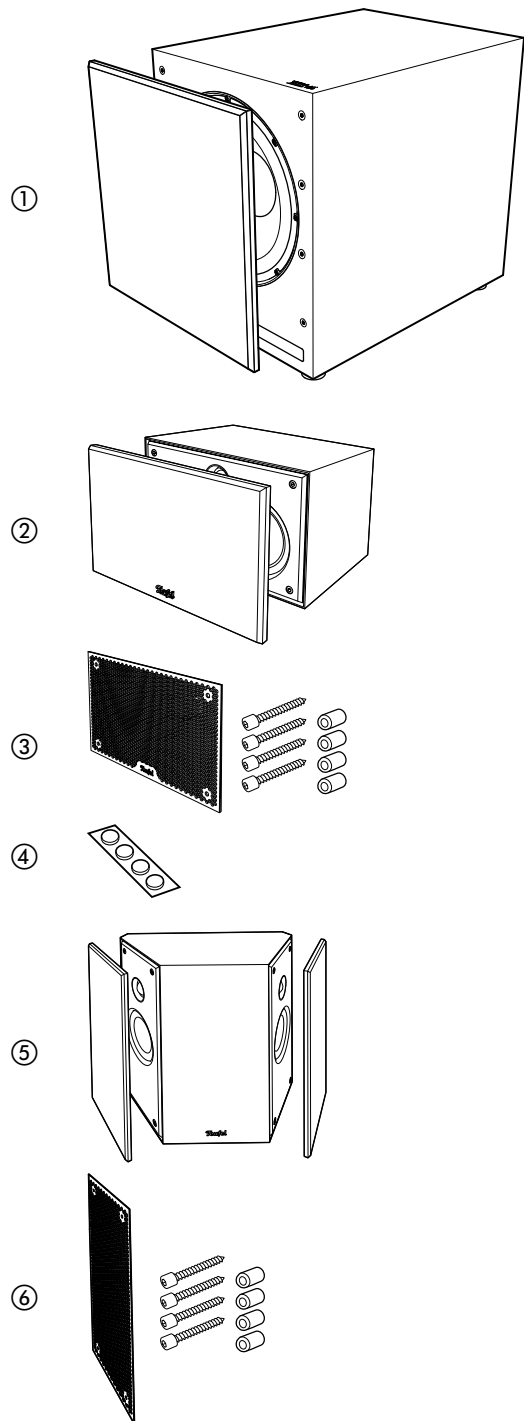

## NOTICE

**A separate user manual is included with the subwoofers.**

- Before connecting and operating the subwoofers, please be absolutely sure to read the user manual.

Mounting material especially attuned to these speakers (cables, speaker stands and isolation pads) is available via our web shop ([www.teufel-audio.com](http://www.teufel-audio.com)) in the “Extras” area.

## Isolation pads

The self-adhesive rubber feet are used to set up the front speakers on a level surface.

## NOTICE

**The isolation pads can produce discoloration on sensitive surfaces.**

- On parquet, varnished wood and similar surfaces, you should stick felt gliders to the rubber feet of the speakers or put blankets or small carpets under them. This will prevent discoloration of the floor over the long term.

## Protective cover

You can take the protective covers off of the speakers by carefully reaching behind the protective covers and slowly pulling them off to the front.

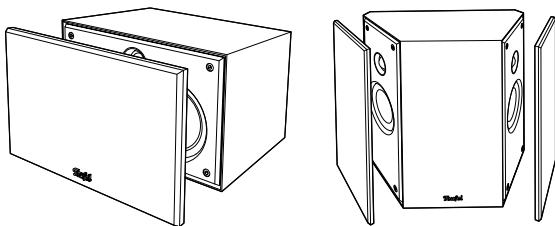

## NOTICE

**Risk of damage!**

- Make sure that you do not touch the highly sensitive diaphragms.

When putting the protective cover on, please make sure that the installation pins slide directly into the corresponding jacks on the speaker.

In general, you can operate the speakers without a protective cover – however, we don't recommend it. According to the THX® requirements profile, the speakers were designed to reach a linear frequency response and consequently their optimal playback quality when used WITH the covers. Playback WITHOUT a cover can result in unbalanced frequency response with intensified playback of treble, which is why we advise not to operate the speakers in this way.

## Optional metal grid

Protective metal grids are also included in the package contents, which you can install instead of the protective cloth covers.

- You will need a AF5 hexagon key for the assembly:
1. Take the protective cover off (see above).
  2. Unscrew the four hexagon socket screws that are now visible.
  3. Insert one of the enclosed distance bushings in each of the four holes.
  4. Place the protective metal grid on the speaker.
  5. Use the enclosed hexagon socket screws to screw the protective metal grid onto the speaker.

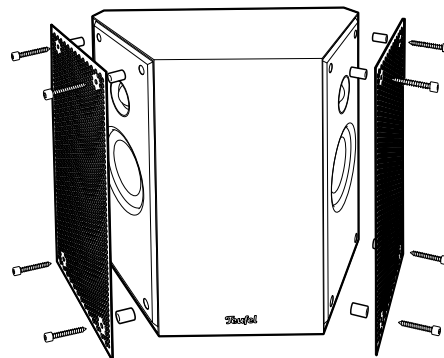
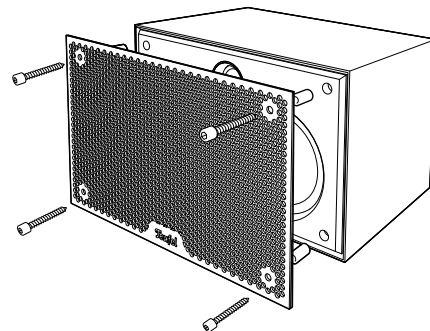

# Setup/Wall Mounting

## Setup location

**i** Our website contains comprehensive notes for correct setup.

### Location tips

- Select a stable, level base.
- Make sure that the environment is clean and free from dust.
- Select a location away from heat sources and direct sunlight.
- Lay the connector cords so that they do not pose a tripping hazard.
- Do not place any heavy objects on the cable or the devices.

## Setup

The following data concern an “ideal home cinema”, in which the viewer or listener sits in a central position at a sufficient distance in front of the video screen or screen (see the following graphic) and no objects (tables or the like) are located in between. Unfortunately, the room, furnishings or other circumstances do not always allow for optimum arrangement.

Modern software in the external players offers diverse possibilities to electronically compensate for possible compromises in the placement. The following general rule applies: You can always experiment on what works best in your listening room in terms of sound and appearance based on our recommendations. Let your ears (and eyes) decide!

### Front speaker

Two of the front speakers S 600 FCR THX® Select ② are set up to the right and left of the screen or positioned at a height of approx. 80 to 160 cm.

- They should form, as far as possible, an equilateral triangle with the listener – what is known as the stereo triangle (distance to listener = distance between speakers).
- Depending on the speaker and set-up height, it may make sense to angle them towards the listening position. You should definitely try this to determine whether it noticeably improves the sound.

### Center speaker

Place one of the front speakers S 600 FCR THX® Select ② in a central position under or above the video screen or screen.

- It should be set up about 20 centimetres behind the left and right speaker.
- If you can only place the center speaker in line with the left and right speaker, you should activate the delay for the center channel (“Center Delay”) – providing that your AV receiver has this option. Many modern AV receivers and amplifiers do not offer this kind of function, but automatically set this delay to a correct value when you activate the automatic calibration function.

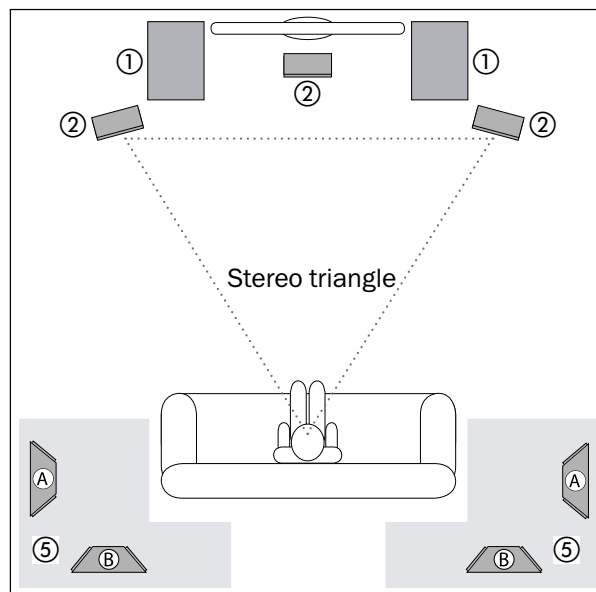



## Subwoofer

You should place the two active subwoofers S 6000 SW THX® Select ① on the floor to the right and left of the television and close to it.

- A location between the front speakers is often ideal.
- However, do not set the subwoofers up in a corner of the room as this may result in uncontrollable frequency rises.

## Rear speakers

The two dipole speakers S 600 D THX® Select ⑤ project sound forward at a 45° into the unobstructed room and back against the walls to produce the desired THX® compliant spatial diffusion.

- Position the dipole speakers inside of the grey areas (see graphic).
- **Version A:** They are set up or hung at head height (140 to 210 cm) to the side of the listener. The distance to the rear wall should be no less than 50 cm.
- **Version B:** You can also set up the rear speakers behind the listener at a height of 140 to 210 cm. Determine the best distance to the side wall by experimenting with different audio tests.

## Wall mounting

### ⚠ CAUTION

**Improper mounting may cause damage.**

- Make sure that the wall mounting is done in a professional manner.
- Before drilling the holes, use a metal detector to ensure that there are no electrical cables or pipes in the wall within the drilling area.
- Use only suitable screws and dowels for fixing.
- Verify the carrying capacity of the walls.

The brackets on the back are used for the wall mounting of the front and dipole speakers (see graphic).

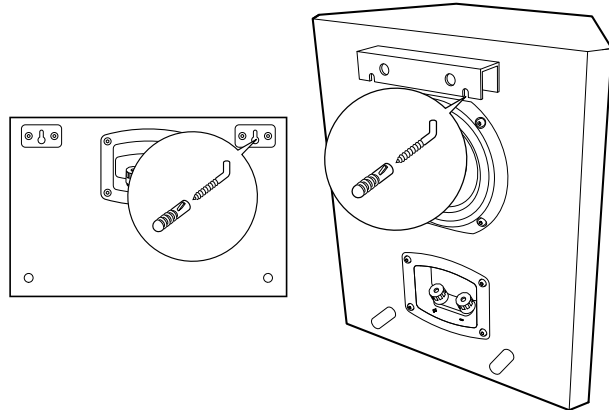

## Wall bracket/speaker stand

The keyhole slot(s) and the threaded hole on the bottom of the speakers (see arrows) are also intended for fixing the speakers to a wall bracket or speaker stand. You will find suitable items in our online shop:  
<https://www.teufelaudio.co.uk/what-works-best.html>

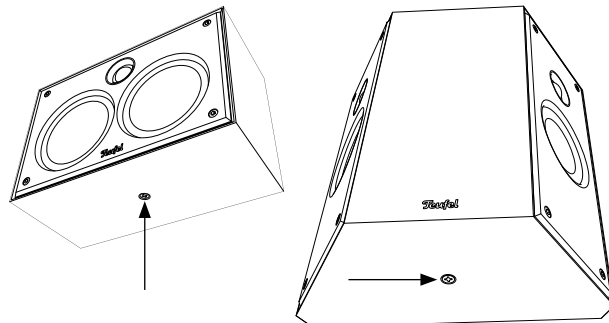

The dipoles would theoretically also be positioned on speaker stands – always close to the wall – but we are unable to offer a speaker stand with the recommended height of at least 1.50 metres. A very large base plate would guarantee stability at this height. However, a stand footprint of approx. 1 × 1 metre is definitely not that nice to look at.

# Connecting

## CAUTION

### **Risk of injury/damage!**

- Lay the cables so that they do not pose a tripping hazard.
- Before connecting the speakers, switch your AV receiver off and pull the mains plug.

## **Connecting the subwoofers**

For setup and connection, please be **absolutely** sure to observe the separate user manual for the subwoofers.

In order to reach the THX® specifications, you should only use a cable to connect the subwoofers to your AV receiver.

- For this, use short, properly shielded RCA cables if possible.
- If your AV receiver only has one subwoofer output, use a Y RCA adapter that you connect directly to the AV receiver if possible.

## **Connecting the speakers**

1. Lay the speaker cables from your AV receiver to each speaker. If possible, use high-quality dual core speaker cables with a diameter of at least 2 mm<sup>2</sup> to do so.

2. On the back of each speaker is a connection terminal with two pole clamps. You can connect the speaker cable directly here or using pin plugs. Direct connection only is described here.

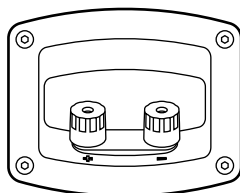

The terminals are marked in red (+) and black (-).

## **NOTICE**

### **Make sure the polarity is correct!**

- Connect each of the like coloured terminals of your active and passive speaker with one another; otherwise the sound quality will suffer. To facilitate this, the individual single wires of the speaker cables are marked with different colours or shapes.

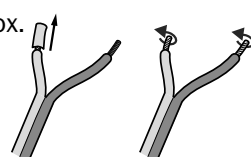
3. Split the wire down by approx. 30 mm on both ends and remove approx. 10 mm of insulation each. Twist the single wire so that no strands are protruding.
- 
- A diagram illustrating the process of stripping and twisting a wire. It shows two wires being stripped of insulation. The first wire is shown with the insulation removed, and the second wire is shown with the strands twisted together. Arrows indicate the direction of the stripping and twisting process.
4. Turn the connector terminal counterclockwise until loose. Run the stripped cable end into the now visible hole. Close the terminal by turning it clockwise. The cable has now been clamped in place.
  5. Connect the other end of the speaker cable to the clamps of your AV receiver.

Finish by also connecting the mains cord of your AV receiver again.

## Adjusting the AV receiver and subwoofers

Most AV receivers have a menu with settings for the speakers (called “Speaker Setup” or similar). By following our recommendations below, you can perfectly align the AV receiver and the subwoofers:

### AV receiver settings

If possible, use your AV receiver’s calibration function so that it automatically adjusts the levels, phase and run times to the room. If your receiver doesn’t provide an automatic calibration function, the following values are recommended:

- Size of the front, center and rear speakers to “normal” or “small” – not “large”.
- Subwoofer to “On”.
- Crossover frequency for subwoofers to 80 Hz.

### Subwoofer settings

- POWER switch (9) to “AUTO”.
- SUB LEVEL control (3) to “THX®”.
- BASS BOOST control (4) to “THX®”.
- PHASE switch (6) to “0°”.

1. Perform an audio test now and adjust the “SUB LEVEL” control (3) until the subwoofer can be “easily heard”. However, it must not drone.
2. If any deep “hits” are too hard or too soft, adjust the setting of the BASS BOOST control (4).
3. Repeat these steps with different video and audio media.
4. Once you have found the best sound, switch the phase shift on and off several times with the PHASE switch (6). Select the setting with the best sound.

## Adjusting the volume

- Use the SUB LEVEL control (3) to adjust the volume of the subwoofer.  
In the “THX®” setting, the subwoofer corresponds to the specifications of THX® Select.
- If the LED CLIP (10) lights up, the input signal is too high. In this case, reduce the subwoofer level on your AV receiver.

## Configuring the sound pattern

- Use the BASS BOOST control (4) to set the low tone sound pattern.  
In the “THX®” setting, the System 6 THX® corresponds to the specifications of THX® Select.

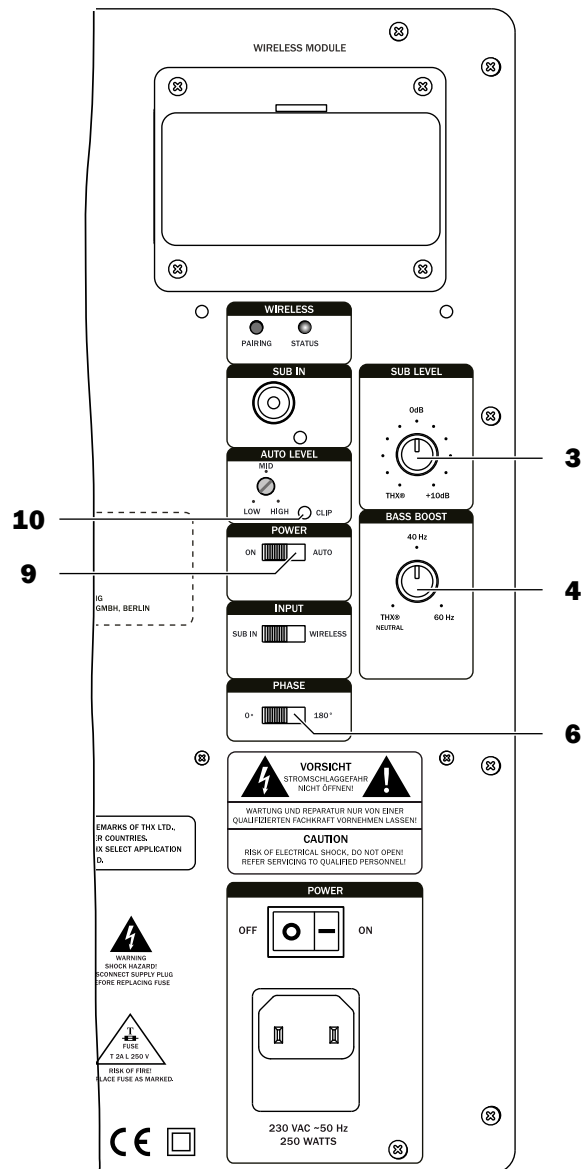

# Care And Cleaning

---

## **NOTICE**

### **External influences may damage or destroy the device.**

- *If the device is to be left unattended for a prolonged period of time (e.g. during a vacation) or if a thunderstorm is forecast, pull the mains plug out of the socket. Otherwise, sudden overvoltage could cause the device to become defective.*
  - *If possible, only use plain water without any additives. In case of stubborn marks, a mild soap solution may be used.*
  - *Do not use caustic cleaning products, white spirit, thinners, petrol or similar under any circumstances. Such cleaning agents may damage the delicate surface of the housing.*
- Ideally, you should remove dust or small amounts of dirt with a dry, smooth leather cloth.
  - Use a damp cloth to rub off stubborn dirt. Make sure that no liquid penetrates the housing.
  - Then immediately wipe the damp surfaces off with a soft cloth without applying pressure.

# Troubleshooting

---

The following advice should help you to solve problems. If this does not help, you will find useful information in the detailed FAQs on our website. Otherwise, please contact our hotline (see page 3). Take note of the warranty instructions.

Please also observe the notes in the separate user manual for the subwoofers.

Problem	Possible cause	Solution
Playback is noisy.	Generally speaking, the speakers are very low noise. In the high range area, the very high-resolution speaker system can expose the poor quality of a signal source (e.g. from MP3 files).	Make sure that the source is emitting a clear signal.
The sound seems dull.	Satellites have been connected with the poles reversed.	Check that the speaker cable on all satellites is correctly connected.
No sound.	Speaker cable not stripped.	

# Technical Data

	Dimensions (WxHxD)	Weight
Front speakers S 600 FCR THX® Select	310 x 200 x 125 mm	4 kg (without metal grid)
Dipole speakers S 600 D THX® Select	335 x 350 x 150 mm	7.2 kg (without metal grids)
Active subwoofers S 6000 SW THX® Select	(see separate user manual)	

You can find further technical data on our website. Technical changes reserved!

 This appliance fulfils the applicable European and national guidelines. This is confirmed by the CE mark (corresponding declarations are kept with the manufacturer).



### Old devices must not be disposed of with household waste!

If the device is no longer operational, every consumer is required by law to dispose of old devices separately from household waste, e.g. at a collection point run by the communal authority/borough. This ensures that old devices are recycled in a professional manner and also rules out negative consequences for the environment.

For this reason, electrical equipment is marked with the adjacent symbol.

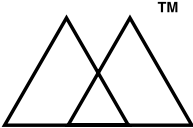

**THX**SELECT

**THX RECOMMENDED USE**

This subwoofer was designed and tested to meet THX performance specifications in large living rooms and home theaters of up to approximately 3,000 cubic feet (85 cubic meters)

**THX CERTIFICATION FEATURES**

- Low frequency extension of 20Hz at -6dB
- High output low distortion design
- Fixed input gain conforms to THX Bass Management system

**THX PERFORMANCE NOTES**

Two subwoofers must be used to deliver THX Reference Level output in a room of approximately 3,000 cubic feet (85 cubic meters)

THX.COM



# Teufel

For questions, suggestions or other issues please contact our customer service department:

**Lautsprecher Teufel GmbH**  
BIKINI Berlin  
Budapester Str. 44  
10787 Berlin (Germany)

Phone.: 00800 200 300 40 (toll-free)  
Fax: +49 (0)30 - 300 930 930  
Service: [www.teufelaudio.com/service](http://www.teufelaudio.com/service)  
Contact: [www.teufelaudio.com/contact](http://www.teufelaudio.com/contact)

No liability is accepted for the accuracy of this information. Technical changes, typographical errors and other errors reserved.

Instruction No. 195118 GB 20170331